

# FPAA-Based PI controller for DC servo position control system

S. Majhi\* V. Kotwal\*\* U. Mehta\*\*\*

\* *Dept. of Electronics and Electrical Engg., Indian Institute of Technology Guwahati, Guwahati 781039, India (e-mail: smajhi@iitg.ac.in)*

\*\* *Dept. of Electronics and Electrical Engg., Indian Institute of Technology Guwahati, Guwahati 781039, India (e-mail: v.kotwal@iitg.ac.in)*

\*\*\* *Dept. of Electronics and Communication Engg., Faculty of Technology, CHARUSAT, Anand 388421, India (e-mail: utkalmehtha@yahoo.com)*

---

**Abstract:** In this paper, the real-time application is implemented for a DC servo position control system using Field Programmable Analog Array (FPAA) technology. An automatic tuning technique based on relay feedback is successfully implemented for obtaining the dynamics of a plant. A non-iterative tuning formulae is used in order to reduce the control efforts and to obtain the desired position. Results of real-time hardware-in-the-loop evaluation, obtained when running the on-line relay feedback test together with initial PI settings and improved response with updated settings, are reported.

*Keywords:* PI control, Relay feedback, FPAA, DC servo position control

---

## 1. INTRODUCTION

A recent survey Kano and Ogawa (2009) shows that the ratio of applications of proportional-integral-derivative (PID) control, conventional advanced control (feed forward, override, valve position control, gain-scheduled PID, etc.) and model predictive control is about 100 : 10 : 1. In addition, the vast majority of the PID controllers do not use derivative action. Even though the PI controller only has two adjustable parameters, it is not simple to find good settings and many controllers are poorly tuned. Many tuning rules have been proposed for standard controllers and processes modeled as a first order transfer function O'Dwyer (2003). In Buckbee (2002), the approach has been given to look the quality of the control actions to preserve actuators from untimely attrition. In a real plant the controlled variables must be limited both in its amplitude (saturation bounds) and in its dynamics (finite bandwidth of the actuators). In this context, less attention has been paid, although in Klan and Gorez (2005); Skogestad (2003) the index has been introduced to measure the variations in the control signal and the criteria is presented to give an excellent trade-off between robustness and performance. It is presented in Vrana (2011) that the majority of tuning methods usually skips the derivative component, or they use set the derivative component parameter to be proportional to the integrative component parameter.

A servomechanism is an automatic device that uses error correction signal to regulate the performance of mechanism, which might be used for positioning control applications in a variety of automated machines like satellite-tracking antennas, remote control airplanes, automatic navigation systems on boats and planes and antiaircraft-

gun control systems. Objective of this paper is to determine the characteristics of a brush DC servomotor system experimentally, which includes the driving circuit, brush DC motor, gear box and position sensing device (potentiometer). The low order transfer function model of the system dynamics is used to design a suitable PI controller. A relay feedback technique is used to estimate the plant dynamics while the controller is still operating normally. Further, the fine tuning of the existing PI controller is accomplished without breaking the closed-loop control. All these benefits are obtained from a low cost Field Programmable Analog Array (FPAA) for its practical considerations.

FPAA is defined as integrated circuits, which are the analog counterparts of the field-programmable gate arrays (FPGAs), digital programmable devices. Unlike the FPGA, which contains a large number of modules and interconnections allowing arbitrary configurations of combinational and sequential logic, FPAA devices typically contain a small monolithic collection of analog building blocks or configurable analog blocks (CABs), a programmable routing network used for passing signals between CABs. FPAAs directed towards standard analog designs typically features a CAB containing an op-amp, programmable capacitors arrays (PCAs), and either programmable resistor arrays for continuous-time circuits or configurable switches for switched-capacitor circuits. The dynamic reconfigurable feature of FPAAs enables analog functions to be updated in real-time using software generated code. With analog functions under the control of systems processor, new devices configurations can be loaded on fly, allowing device's operation to be "time-sliced" or to

manipulate the tuning of any part of the circuit without interrupting operation of FPAA, thus maintaining system, integrity Manual (FPAA). Using reusable and reconfigurable modules, the design of control applications can be greatly simplified which reduce the development time for embedded hardware and software.

On the topic of automatic tuning of PI/PID, many notable contributions have been found in the literature. In this work, relay based on-line tuning schemes are studied to implement the automatic control application. Schei (1992) proposed an on-line iterative method for closed-loop automatic tuning of the PID controller. The on-line experiment time by his method is very long which may not be acceptable in practice. The on-line tuning methods Tan et al. (2000, 2002); Mehta and Majhi (2010) have been proposed which are more effective than the basic relay auto-tuning method. The identification procedure in Tan et al. (2000) is not straightforward and one needs to have prior knowledge about the system to decide about the suitable frequency response prototypes. Ho et al. (2003) have presented relay auto-tuning of PID compensator for wanted phase and bandwidth. However, the method is complex due to computing the gradient of the quadratic criterion. The exact analytical method Majhi (2005) has been proposed in which a relay is connected in series with a controller. Recently, on-line computing rules Tsay (2009) were developed by introducing a relay with a pure time lag to find new PI and lead compensators based on specified gain and phase margins. The applicability of the basic relay tuning method is extended by Mehta and Majhi (2012) to tune PI controllers without breaking the closed-loop control.

This paper presents the position control of a DC servo motor based on on-line relay feedback. It has been shown how simple control strategy can be used to obtain the desired position with less computational efforts and time. A parallel combination of a relay and PI controller induces a limit cycle oscillation in the steady state over a limited time span without breaking closed-loop control. Based on limit cycle oscillation, the dynamics of DC servo motor is estimated by a low order transfer function model. A set of non-iterative tuning formulas is derived from estimated dynamics in order to tune PI controller.

## 2. ON-LINE RELAY AUTOTUNING

Aimed at governing the small limit cycle on the operating condition without breaking the closed-loop control. Fig.1 shows the on-line tuning scheme in which the relay height is increased from zero to some acceptable value when re-tuning is necessary. We consider a first order plus dead time (FOPDT) model to represent the plant dynamics as

$$G(s) = \frac{k e^{-\theta s}}{\tau s + 1} \quad (1)$$

where  $k$  is steady state gain,  $\theta$  is time delay and  $\tau$  is time constant of the plant. Let us take a PI controller transfer function is

$$C(s) = k_c + \frac{k_i}{s} \quad (2)$$

where  $k_c$  and  $k_i$  denote the proportional and integral gains of the controller. The closed-loop transfer function of the feedback control system (which the relay sees) is given by

$$\frac{y(s)}{u_1(s)} = \frac{k e^{-\theta s}}{\tau s + 1 + k k_c e^{-\theta s} + \frac{k k_i}{s} e^{-\theta s}} \quad (3)$$

where  $u_1$  is the relay output. Assume that the relay

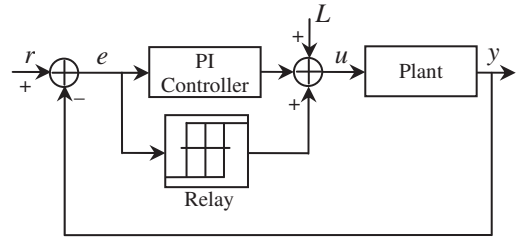

Fig. 1. On-line relay autotuning structure

test induces a limit cycle output with a half period  $T$  and the relay amplitude and hysteresis width of  $\pm h$  and  $\pm \varepsilon$ , respectively. Conventional relay experiment using an ideal relay induces chattering in the presence of noise which is usually considered undesirable from a practical point of view Wang et al. (2003). This can be overcome by introducing a relay with hysteresis. Since a relay with hysteresis instead of an ideal relay is used for the identification, the resultant system is less sensitive to measurement noise. With hysteresis, relay switches at time  $t = t_0$  when  $y(t_0) = \varepsilon$ . First, a steady state gain  $k$  is obtained from the plant input and output signals for non-zero reference input Majhi (2009).

*Estimation of Steady State Gain  $k$ :* The average value of the process input  $u(t)$  is non-zero for non-zero reference input,  $r$  due to the integral action in the controller. So, the steady state gain of the process can be obtained from the ratio of the average values of the process output and input signals. The method ensures accurate estimation of the steady state gain in the presence of measurement noise and static load disturbance. For some  $t > 2T$ , when steady state limit cycle is produced, let  $y_{avg}$  and  $u_{avg}$  be the averages of the process output signal  $y(t)$  and input signal  $u(t)$ , respectively, as shown in Fig. 2. The average value of the limit cycle output is the set-point value due to the integral action of the PI controller. Therefore, the steady state gain can be estimated as

$$k = \frac{y_{avg}}{u_{avg}} = \frac{2r}{u_{max} + u_{min}} \quad (4)$$

If average value of the limit cycle output signal is zero when  $r = 0$ , then a temporal disturbance may be given to the setpoint for a short period of time to obtain  $y_{avg}$ .

*Estimation of  $\tau$  and  $\theta$ :* Another well-known frequency-based analysis namely describing function (DF) for identification based on an ideal relay Majhi (2009) is extended here for the case of the relay with hysteresis. From a stable limit cycle output, the peak amplitude  $a_p$  and half-period of the oscillation  $T$  are measured for relay amplitude  $\pm h$  and hysteresis  $\pm \varepsilon$ . A relay with hysteresis induces the limit cycle output at frequency  $\omega_c$  when

$$G(j\omega_c)[N + C(j\omega_c)] = -1 \quad (5)$$

where  $N = \frac{4h}{\pi a_p^2} (\sqrt{a_p^2 - \varepsilon^2} - j\varepsilon)$  is the DF of the relay with hysteresis.

Substitution of  $G(j\omega_c)$  and  $C(j\omega_c)$  in (5) gives

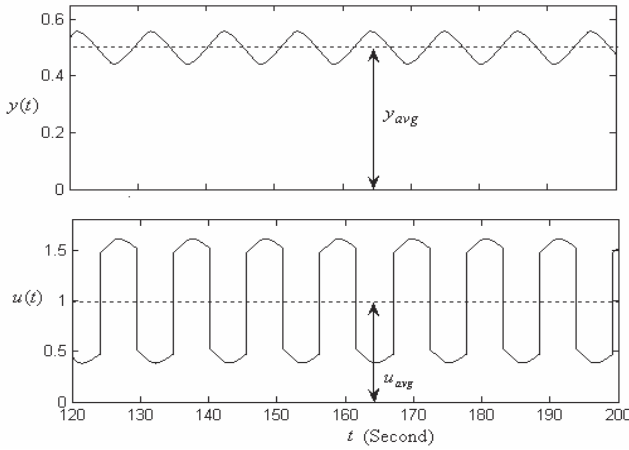

Fig. 2. Input and output of the plant

$$\frac{ke^{-j\omega_c\theta}}{j\omega_c\tau + 1}(\alpha + j\beta) = -1 \quad (6)$$

where

$$\begin{aligned} \alpha &= \frac{4h}{\pi a_p^2}(\sqrt{a_p^2 - \varepsilon^2}) + k_c, \\ \beta &= -\frac{k_i}{\omega_c} - \frac{4h\varepsilon}{\pi a_p^2}, \\ \omega_c &= \pi/T \end{aligned} \quad (7)$$

By equating the real and imaginary parts of both side of (6), we obtain explicit expressions for  $\tau$  and  $\theta$  as

$$\begin{aligned} \tau &= \frac{\sqrt{k^2(\alpha^2 + \beta^2) - 1}}{\omega_c} \\ \theta &= \frac{\pi + \tan^{-1}(\beta/\alpha) - \tan^{-1}(\omega_c\tau)}{\omega_c} \end{aligned} \quad (8)$$

### 3. OPTIMAL PI CONTROL DESIGN

Based on the parametric model of the plant, the new PI gains may be optimized by minimizing an integral performance criterion like the integral squared time error (ISTE) index. Aiming to achieve superior control performance by optimizing error signal in such a way that it gives minimum control output variations. An index has been defined to measure the total variation (TV) in  $u(t)$  that gives the performance of the controller Skogestad (2003). If we discretize the input signal as a sequence,  $[u_1, u_2, \dots, u_i, \dots]$ , then

$$TV = \sum_{i=1}^{\infty} |u_{i+1} - u_i| \quad (9)$$

which should be as small as possible to minimize variations in  $u(t)$ . Ideally  $u(t)$  should be equal to  $u(\infty)$  for all  $t > 0$ , hence  $\dot{u}(t) = 0, \forall t > 0$ . This concept provides the following constraint using the control law as

$$\begin{aligned} \dot{u}(t) &= k_c \dot{e}(t) + k_i e(t) = 0 \\ k_c^2 (\dot{e}(t))^2 &= k_i^2 (e(t))^2 \end{aligned} \quad (10)$$

If we represent the above constraint in time weighted integral of error signal, it gives a tight criterion for the initial unavoidable errors during setpoint changes. Thus, (10) is replaced by the following integral constraint as

$$\left(\frac{k_c}{k_i}\right)^2 \int_0^{\infty} (t\dot{e}(t))^2 dt = \int_0^{\infty} (te(t))^2 dt \quad (11)$$

First, it turns out that the left-hand side of (11) is the well-known ISTE performance index Zhuang and Atherton (1993)

$$ISTE = \int_0^{\infty} (te(t))^2 dt \quad (12)$$

which can be characterized with the integral control action of a PI controller. Similarly, the right-hand side of (11) introduces another performance index involving the derivative of the error signal to characterize the proportional control action as

$$ISTD = \left(\frac{k_c}{k_i}\right)^2 \int_0^{\infty} (t\dot{e}(t))^2 dt \quad (13)$$

The index in (13) is defined as weighted Integral of Squared of Time Derivative of error signal (ISTD). Both the indices can be evaluated very efficiently using the s-domain formulation. After the error signal expressed in the frequency domain and the criterion is to be minimized for a satisfactory closed loop performance of the system. The integral can be optimized with the help of Åström's Åström (1970) recursive algorithm and the FMINS MATLAB function that uses a simplex search technique. Using a least squares fit technique, the PI parameters and the modify ISTE values to obtain optimum control signal variation for the low order plants may be found directly by the following simple formulae.

$$\begin{aligned} k_p &= (-1.451(\theta/\tau)^{0.121} + 2.02)/k \\ k_i &= (-0.648(\theta/\tau)^{0.448} + 1.144)/k\tau \end{aligned} \quad (14)$$

### 4. DC SERVO POSITION CONTROL USING FPAA

A block diagram of the complete hardware control scheme is represented by Fig. 3. The photograph of a laboratory experiment for a DC servo position control system is shown in Fig. 4. A real-time experimental setup made up of a brush DC servo motor and Anadigm AN221E04 FPAA and a personal computer. The tuning algorithm runs on a computer that also configures the FPAA dynamically using RS-232. The variety of analogue functions like amplification, summing, integration, filtering, etc. were used to implement PI controller in FPAA. The AnadigmDesigner-2 software provides a set of C functions to be used for reading current PI setting and reconfiguring the chip on-line if design parameters require to be dynamically changed. The desired input reference of position in degree has been calibrated with equivalent dc voltage (Fig. 5). To perform relay test the sampling time, relay amplitudes and hysteresis settings were 16 msec,  $\pm 0.17$  V and  $\pm 20$  mV, respectively. Following the on-line tuning method, the process dynamics was modelled by  $0.9937e^{-0.1990s}/(2.0926s + 1)$  using initial settings  $K_p = 6.3662$ ,  $K_i = 0.5500$ . The new controller parameters were computed as  $K_p = 0.9445$  and  $K_i = 0.4391$  using the proposed tuning formulas in 14.

The closed-loop response using the initial PI settings for position  $90^\circ$  ( $P_r = 0.192V$ ) and limit cycle oscillations during the on-line relay test and then the improved response for the new step change  $150^\circ$  ( $P_r = 0.313V$ ) with

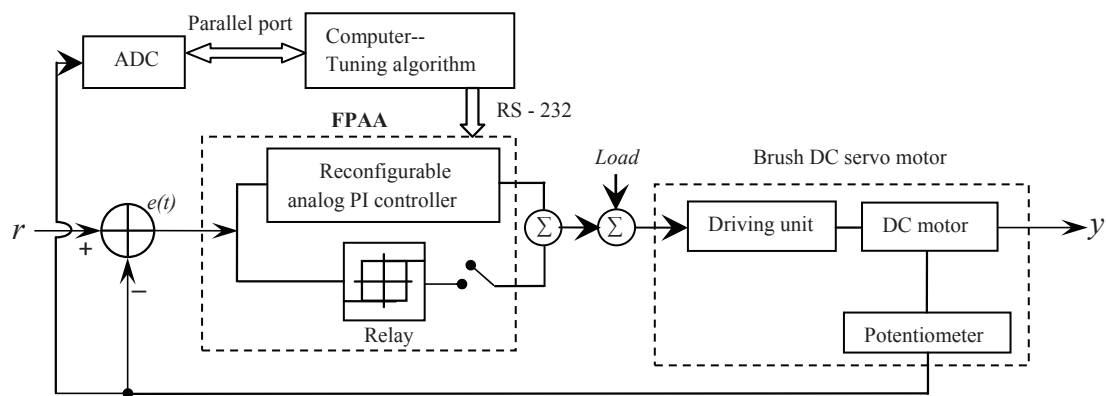

Fig. 3. Block diagram of a DC servo position system

new PI settings, are shown in Fig. 6. The corresponding control signal and effects of static load disturbance are plotted in Fig. 7. The tracking performance is clearly enhanced with almost no overshoot and also reduced the control efforts to obtain the desired position.

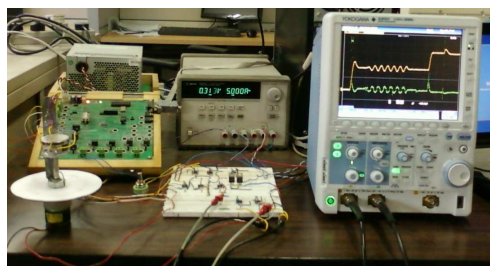

Fig. 4. Photograph of an experimental setup

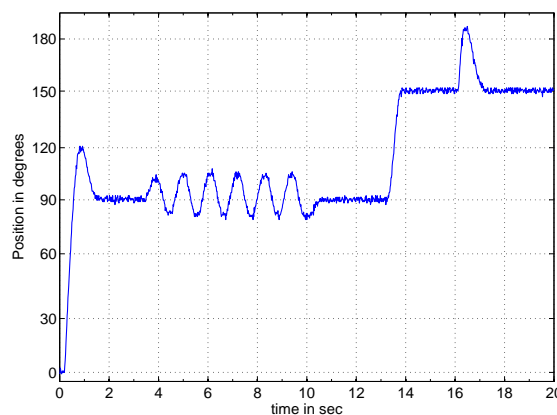

Fig. 6. Setpoint responses for desired position

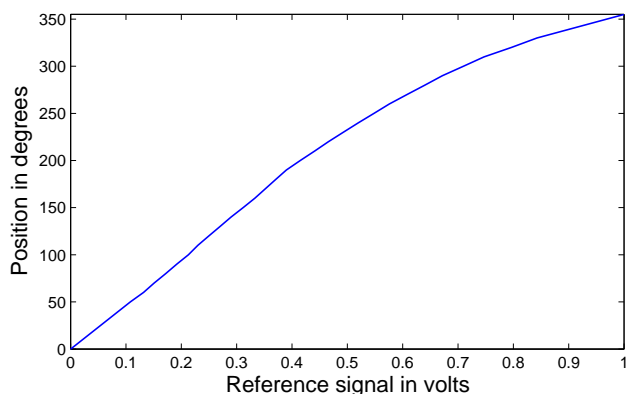

Fig. 5. Calibration of reference input for angular position

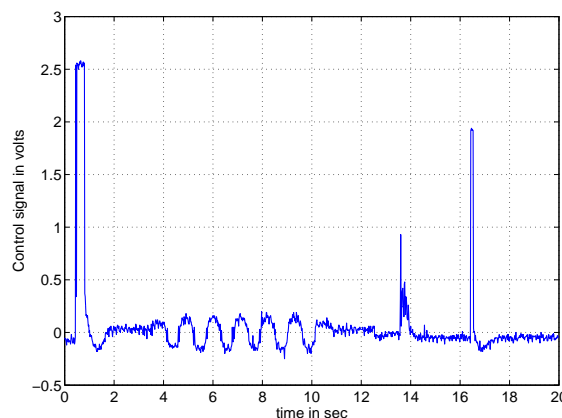

Fig. 7. Control signal for obtaining desired position

## 5. CONCLUSION

In this paper, relay autotuning technique was successfully implemented using FPAA and tested on a DC servo position control system. Differently from the standard relay autotuning approach, it allows the tuning of the controller without detaching it from the closed-loop operation. For

position control, the results showed that, with the on-line tuning of PI controller added, the desired output position was obtained without overshoot. The non-iterative method uses only half limit cycle output, therefore it reduces an experiment time and also offers a smooth control signal variation. Experimental results proves the applicability of the FPAA technology to design a reconfigurable industrial controller. Here, the controller modules are reusable and

reconfigurable, which can be utilized in other control applications.

## REFERENCES

- Åström (1970). *Introduction to Stochastic Control Systems*. Academic Press Inc.
- Buckbee, G. (2002). Poor controller tuning drives up valve costs. *Control Magazine*, 15, 47–51.
- Ho, W.K., Honga, Y., Hanssonb, A., Hjalmarssonc, H., and Denga, J.W. (2003). Relay auto-tuning of PID controllers using iterative feedback tuning. *Automatica*, 39, 149–157.
- Kano, M. and Ogawa, M. (2009). The state of art in advanced process control in japan. In *IFAC Symposium ADCHEM2009*. Istanbul, Turkey.
- Klan, P. and Gorez, R. (2005). On aggressiveness of PI control. In *16-th IFAC World Congress, Praha*.
- Majhi, S. (2005). On-line PI control of stable processes. *J. Proc. Contr.*, 15, 859–867.
- Majhi, S. (2009). *Advance Control Theory - A Relay Feedback Approach*. Cengage Learning.
- Manual (FPAA). *Datasheet, "Dynamically Reconfigurable FPAA"*, <http://www.anadigm.com>.
- Mehta, U. and Majhi, S. (2010). On-line identification and control methods for PID controllers. In *IEEE ICARCV2010*, 1507–1511.
- Mehta, U. and Majhi, S. (2012). On-line relay test for automatic tuning of pi controllers for stable processes. *Transactions of Inst. of Meas. Cont.*, In Press. doi: 10.1177/0142331211425401.
- O'Dwyer, A. (2003). *Handbook of PI and PID Controller Tuning Rules*. Imperial College Press.
- Schei, T.S. (1992). A method for closed loop automatic tuning of PID controllers. *Automatica*, 28 (3), 587–591.
- Skogestad, S. (2003). Simple analytic rules for model reduction and PID controller tuning. *J. Proc. Contr.*, 13, 291–309.
- Tan, K.K., Ferdous, R., and Huang, S. (2002). Closed-loop automatic tuning of PID controller for nonlinear systems. *Chem. Eng. Sci.*, 57, 3005–3011.
- Tan, K.K., Lee, T.H., and Jiang, X. (2000). Robust on-line relay automatic tuning of PID control system. *ISA Trans.*, 39 (2), 219–232.
- Tsay, T.S. (2009). On-line computing of PI/lead compensators for industry processes with gain and phase specifications. *Comp. Chem. Eng.*, 33, 1468–1474.
- Vrana, S. (2011). Frequency response based the derivative component tuning approach. In *50th IEEE Conference on Decision and Control and European Control Conference, USA*.
- Wang, Q.G., Lee, T.H., and Lin, C. (2003). *Relay feedback: Analysis, Identification and control*. London: Springer-Verlag.
- Zhuang, M. and Atherton, D.P. (1993). Automatic tuning of optimum PID controllers. *IEE Proc.-Contr. Theory Appl.*, 140, 216–224.