

## **Gender Perceptions towards Diversity Management Practices in the Public Sector**

[https://doi.org/10.33318/jpacs.2022.42\(1\)-2](https://doi.org/10.33318/jpacs.2022.42(1)-2)

*Inayah Ali<sup>1</sup>, Jashwini Narayan<sup>2</sup> and Subhash Appana<sup>3</sup>*

### **Abstract**

This study aims to examine the differences in the perception of male and female employees towards diversity management and their work outcomes in a highly male-dominated culture in the Public Sector. A quantitative survey of 114 public sector employees was analysed using structural equation modelling. Overall, the findings reveal that diversity management has a positive and significant impact on both genders' work outcomes of affective commitment, organisational commitment, job satisfaction, work group performance and inclusiveness of organisational culture. However, the male employees reported lower levels of organisational commitment than the female employees. This study highlights key suggestions for policymakers and public managers, such as diversity strategy, top leadership commitment, diversity training programs, team bonding exercises, strengthening of family-friendly programs and other suggestions. The theoretical contribution of this research is the integration of representative bureaucracy theory, commitment management theory and social cognitive theory for a robust argument for diversity management in the public sector. Studies on gender perceptions in developing small island countries are rare. This study is the first of its kind in the subject country. It identifies the distinct gender norms in society and the role of diversity management.

**Keywords:** Developing country, Diversity Management, Gender perceptions, Male-dominated culture, Public sector

---

<sup>1</sup>PhD candidate, Discipline of Management and Public Administration, School of Business and Management, The University of the South Pacific, Fiji, email: inayahali100@yahoo.com

<sup>2</sup>Senior Lecturer, Discipline of Management and Public Administration, School of Business and Management, The University of the South Pacific, Fiji, email: jashwini.narayan@usp.ac.fj

<sup>3</sup>Senior Lecturer, Discipline of Management and Public Administration, School of Business and Management, The University of the South Pacific, Fiji, email: subhash.appana@usp.ac.fj

## **Introduction**

Today, more women than ever are educated and participate in the labour market (OECD, 2020). Despite progress in OECD countries, women and other disadvantaged groups face discrimination entrenched in social norms, lack of networks and accessibility issues, resulting in the substantial labour market and wage gaps even in the public sector – this threatens social cohesion (OECD, 2020).

This study focuses on a developing South Pacific country, Fiji, where the female labour force participation rate is 38 per cent, and the female share of managers is 39 per cent (International Labour Organization, 2020). However, increasing labour force participation does not mean narrowing gender gaps in the workplace (Fiji Women's Rights Movement, 2018). These gaps include unequal access to employment, unequal pay between men and women, and limited access to social protection and senior leadership positions. A study conducted by Tebbutt Research commissioned by Fiji Women's Rights Movement revealed that the sector reporting the highest incidence of harassment was the tourism sector, followed by the public service, health and retail sectors (Fiji Women's Rights Movement, 2016). Discrimination in the workplace, including those against women and disabled workers, leads to economic and social costs such as absenteeism, emotional distress, and potential social breakdown (International Labour Organization, 2021). A workplace free from discrimination and harassment leads to better work performance and higher productivity (International Labour Organization, 2021). Thus, managing gender diversity is crucial for an inclusive and equitable work environment.

Initial work on Diversity Management began in the USA to create a more positive business perspective of productivity from a heterogeneous workforce (Thomas, 1990). Among the many aims of diversity management, one is preventing discrimination against disadvantaged groups such as women and minorities and their equitable treatment (Soni, 2000; Thomas 1990). Diversity practices have prevented organisations from exacerbating traditional gender inequalities (Kim & Park, 2017).

Most studies on diversity management have been conducted in the Western context. For instance, empirical studies in the USA found a positive effect of diversity management on employees' work outcomes and behaviour (Choi & Rainey, 2010; Kim & Park, 2017; Pitts, 2009). It is noteworthy that while there

have been numerous geographically spread studies on diversity management (Ashikali & Groeneveld, 2015b; Ghasemi, 2014; Kehoe & Wright, 2013; Koç et al., 2014; Kundu & Mor, 2016; Magoshi & Chang, 2009; Ordu, 2016), only a few studies have examined gender-based perceptions of diversity management on work outcomes (Ashikali & Groeneveld, 2015a; Choi & Rainey, 2010; Kim et al., 2015). To date, very few studies have highlighted gender-based perceptions of diversity management in a male-dominated society such as one in South Korea (Kim et al., 2015). In the context of smaller developing countries, there are no studies that distinguish between male and female perceptions of diversity management in a male-dominated society. This study cannot, however, be generalised to other contexts because of different sociocultural orientations, power structures and socio-political efforts to eliminate gender discrimination and workforce diversity. Furthermore, every organisation has its own organisational culture, values and workforce diversity which makes it difficult to design and implement a commonly accepted diversity-related programme for all organisations (Jin, Lee, & Lee, 2017).

This research is significant because it highlights the male and female employees' perceptions of diversity management on their individual (affective commitment, organisational commitment and job satisfaction), group (work group performance) and organisational (inclusive organisational culture) work outcomes in a developing country's public workforce in a male-dominated culture. This study contributes to the literature in two ways. Firstly, the integration of representative bureaucracy theory, commitment management and social cognitive theory to explore diversity management and employee work outcomes. The combination of these theories strengthens the argument for effective diversity management in the public sector for improved service delivery and effectiveness. Secondly, we provide evidence from a smaller island developing context and extend the literature from US-centric and Asian contexts.

### **Gender and Cultural Context**

Although significant progress has been made in Fiji to dismantle systematic gender-based discrimination in society and the workplace, the issue remains salient. While educated women from all ethnic groups have greater opportunities for employment and are getting their voices heard, this developing country remains a male-dominated society (Naidu, 2013) Despite the progress of women in Fiji's parliament, patriarchy is a major force that hinders the

advancement of women in the political sphere (Chattier, 2015). Men are seen as legitimate political leaders by indigenous Fijians (iTaukei) and non-indigenous (Indo-Fijians) ethnicities (Naidu, 2013). The gender norms of ethnicities, such as women's domesticated role in the homes of Indo-Fijian households and few rights to inherit land and property or take part in public decision-making in iTaukei households, strengthen the patriarchal culture (Chattier, 2015). However, in the past few years, females have been able to transgress and negotiate gender roles as there has been progress in female employment in the public sector workforce and socio-economic developments such as education (Chattier, 2013). For instance, statistics show an increase in gender diversity in Fiji's public sector workforce. The total number of public employees in 2017 was 47,928, of which 56 per cent were male, and 44.33 per cent were female employees (Fiji Bureau of Statistics, 2020). Much of this change has been influenced by the women's movement and civil society activism in Fiji as they are advocates of gender parity (Chattier, 2015). Historical employment legislation also played a central role for gender equality in female employment.

## **Literature Review**

Most public agencies around the world have implemented some form of diversity management initiatives (Soni, 2000) with the goal of increasing organisational effectiveness (Naff & Kellough, 2003). These include the Government-Wide Diversity and Inclusion Strategic Plan 2011 in the USA, Framework for Action 2008 in Canada (Ohemeng & MacGrandle, 2015), Equality Act 2010 in the UK (Klarsfeld et al., 2014), Workplace Gender Equality Act 2012 in Australia (Stone, 2017) and Human Rights Act 1993 in New Zealand (Deborah et al., 2000). In Fiji, gender diversity in the public sector was realised through the Equal Employment Opportunity Policy in the late 1990s by Public Service Commission (International Labour Organization, 2019) and later in the Employment Relations Act 2007, which prohibits discrimination in employment. New public management (NPM) reforms in Fiji have introduced human resource diversity management practices in recruitment and selection, training and development and career development.

Diversity management is the latest development in a sequence of strategies aimed to: better represent the excluded minority in employment, recognise the cultural differences between groups of employees and make practical allowances for these differences in organisational policies (Wrench, 2007). There are two widespread practices of diversity management. Diversity

practices in the recruitment process make the workforce more diverse (Avery and McKay, 2006). Diversity training is another prominent practice to raise awareness of managers and employees on diversity-related stereotypes and biases and focuses on the inclusion of minorities and vulnerable groups (Alhejji et al., 2016). Recent research shows that female employees reported more favourable perceptions of diversity management practices than male workers (Kim et al., 2015; Mousa et al., 2020). In this research, diversity management is conceptualised through Pitts's (2006) lens. It has three interrelated components of recruitment and outreach, valuing differences and pragmatic policies and programs such as mentoring opportunities to provide a culture of support for minority employees.

### **Theoretical Framework and Hypothesis Development**

Representative bureaucracy theory, commitment management theory and social cognitive theory are used to explain the relationship between diversity management and its effect on male and female employees' various work outcomes.

The argument for diversity management in the public workforce has been envisioned with the theory of representative bureaucracy (Pitts, 2005). It postulates the public service to be inclusive of diverse races, nationalities and religions that reflect pluralism in society (Long, 1952). Representative bureaucracy warrants equal opportunity and representation of diverse groups' interests in policy decisions (Adusah-Kaikari & Ohemeng, 2014). Rice (2010) expands the rationale for equity-based diversity management to improve decision-making in public organisations rather than diversity through population changes. Pitts (2009) proved that employees have a high level of work group performance when supported by diversity management practices for responsive public service. However, this theory fails to show how diversity management affects other individual and organisational work outcomes for responsive public service. Therefore, the use of commitment management theory explains the reciprocal relationship between diversity management and various work outcomes, and social cognitive theory details the psychological processes involved between an organisation's diversity management strategies and employees' behaviour towards their work outcomes. These two theories suggest diversity management will improve employees' work outcomes, which means that employees will be productive and effective in their public service delivery. In addition, it implies that with improved work outcomes, the

employees will feel included and represented, thus, effective in decision-making for diverse groups of people. Therefore, this aligns with the theory of representative bureaucracy's argument.

Commitment management theory views the relationship between an organisation and its employees as an exchange of commitment (March & Simon, 1958). When an organisation expresses its commitment to its workforce through diversity management strategies and practices, the employees, in return, reciprocate with their commitment to the organisation (Romanenko, 2012). Empirical studies support this (Ghasemi, 2014; Kundu & Mor, 2016; Magoshi & Chang, 2009). Diversity management human resource practices affect various individual and organisational level work outcomes (Stone, 2017). In this study, we extend this theoretical perspective and add four work outcomes: affective commitment, job satisfaction, work group performance and inclusive organisational culture. The reciprocal relationship between diversity management and these work outcomes will be investigated.

Social cognitive theory, as a psychological approach to learning and cognition, explains the triadic reciprocal determinism between the external environment, internal person factors and behaviour (Gibson, 2004). Self-efficacy is the most researched sub-theory related to the capability beliefs of an individual to successfully complete a specific task (Bandura, 1997). The concept of self-efficacy can be integrated with psychological climate to explain the overall psychological approach. The psychological climate is the property of the individual that depicts experience-based meanings at the workplace based on the organisational structures, processes and events (Parker, et al., 2003). Individuals judge the extent to which the work environment is beneficial to their sense of well-being (Carless, 2004). When organisations effectively implement HR diversity policies and practices (as a factor of the external environment), it can create a positive psychological climate (Doghan et al., 2019) and simultaneously boost the self-efficacy of the employees to do better at the workplace, which could influence employee job satisfaction and performance. Furthermore, positive perceptions and capability beliefs can affect employee affective, organisational commitment, workgroup performance and feelings of inclusivity in the work environment. The proposition by Doghan, Bhatti and Juhari (2019) on job satisfaction is tested in this research. Four additional work outcomes are explored through this theoretical lens as well.

In line with these theories, diversity management policies and practices provide

a culture of inclusion and equity in opportunities for both genders in male-dominated cultures to enhance their work outcomes. Representative bureaucracy theory has not been previously integrated with other theories in a diversity paper to explain the work outcomes. To the authors' best knowledge, this is the first paper to integrate representative bureaucracy theory with others to provide a robust argument for diversity management on these work outcomes in the public sector. The application of these theoretical concepts in Fijian organisations further makes it unique.

## **Research Hypotheses**

### **Affective commitment**

Affective commitment reflects the emotional attachment to, identification with and involvement in the organisation (Allen & Meyer, 1991). In a previous study by Cho and Mor Barak (2008) in a highly dominated male culture in Korea, male workers had a higher level of affective commitment than female workers. This is because of the Korean cultural context that emphasises a woman's primary responsibility to her spouse and family. However, in the presence of workplace diversity management programs, the findings can differ. Empirical studies show that diversity management has a positive impact on employees' affective commitment (Groeneveld & Ashikali, 2015a; Ashikali & Groeneveld, 2015b; Kehoe & Wright, 2013). Ashikali and Groeneveld's (2015a) analysis of gender groups showed that diversity management is associated with high levels of inclusion, boosting the affective commitment of both male and female employees in the Dutch public sector. It is assumed that the findings will be same in other male-dominated cultures. Thus, the following hypotheses are proposed:

- Hypothesis 1a: Diversity management has a positive and significant effect on male employees' affective commitment.
- Hypothesis 1b: Diversity management has a positive and significant effect on female employees' affective commitment.

### **Organisational commitment**

Organisational commitment refers to an employee's strong belief to accept organisational goals and values and exert considerable effort in support of the organisation with a wish to remain (Angel & Perry, 1981). Research by Kim, Lee and Kim (2015) in highly male-dominated Korean society revealed no

difference in the level of organisational commitment of male and female employees. Empirical studies show that diversity management has a positive impact on employees' organisational commitment (Magoshi & Chang, 2009; Ghasemi, 2014; Kundu & Mor, 2016). In a male-dominated culture, it is assumed that diversity management practices at the workplace will leverage male and female workers' perceptions of organisational commitment to be similar. This leads to the following hypotheses:

- Hypothesis 2a: Diversity management has a positive and significant effect on male employees' organisational commitment.
- Hypothesis 2b: Diversity management has a positive and significant effect on female employees' organisational commitment.

### **Job Satisfaction**

Job satisfaction is defined as the degree to which employees have positive attitudes toward their jobs (Stone, 2017). Empirical research shows that diversity management efforts have a positive impact on employees' job satisfaction (Pitts, 2009; Koç et al., 2014; Ordu, 2016). Pragmatic policies and practices under diversity management, such as mentoring opportunities, family-friendly policies and flexible working hours, influence job satisfaction (Pitts, 2006). Diversity management encourages an environment of cultural diversity where employees' differences are recognised and valued, thus enabling them to work to their full potential in a more productive environment (Wrench, 2007). Diversity management values gender differences and provides equity in opportunities and policies for male and female workers, influencing job satisfaction. Hence, the following hypotheses are proposed:

- Hypothesis 3a: Diversity management has a positive and significant effect on male employees' job satisfaction.
- Hypothesis 3b: Diversity management has a positive and significant effect on female employees' job satisfaction.

### **Work Group Performance**

As the demographic profile of workers becomes more diverse in terms of age, gender, ethnicity and other dimensions of diversity, HR scholars and practitioners need to cope with managing diversity within the workforce (Klarsfeld et al., 2014). It requires organisations to grasp the advantages of diversity and mitigate associated threats. In line with representative bureaucracy



theory, a public service that reflects a pluralistic society will be responsive to citizens' needs. Diversity management provides and promotes diversity through recruitment outreach, valuing differences and pragmatic policies improve the group performance of workers. Empirical evidence by Pitts (2009) supports this. In the case of a male-dominated culture, it is assumed that diversity policies and practices will be based on fairness and equity. It considers the differences between male and female workers to help them perform effectively in teams, thus being responsive to population needs and concerns. This leads to the following hypotheses:

- Hypothesis 4a: Diversity management has a positive and significant effect on male employees' workgroup performance.
- Hypothesis 4b: Diversity management has a positive and significant effect on female employees' workgroup performance.

### **Inclusive Organisational Culture**

The diversity management perspective follows an inclusionary approach whereby differences are recognised and valued, and new perspectives are integrated into decision-making and problem-solving processes (Pless & Maak, 2004). To develop a strong culture of inclusiveness, leaders must practice inclusive leadership to recognise the differences between employees, regardless of their social, cultural and physical backgrounds (Myung et al., 2017). Ashikali and Groeneveld (2015b) prove that diversity management positively impacts employees' perception of an inclusive organisational culture. Particularly in male-dominated cultures, gendered norms and stereotypes of women often exclude them in the decision-making process. However, diversity management recognises and values gender differences and actively encourages the participation of women in the workplace. Thus, the following hypotheses are proposed:

- Hypothesis 5a: Diversity management has a positive and significant effect on male employees' inclusive organisational culture.
- Hypothesis 5b: Diversity management has a positive and significant effect on female employees' inclusive organisational culture.

## **Research Method**

### *Design*

In this study, the survey method was employed to collect data from participants. Most diversity studies are empirical; thus, this research method was adopted (Yadav & Usha, 2020). The survey questionnaire focused on employees' perceptions of diversity management and their individual, group and organisational work outcomes. Ethics approval to conduct this study was obtained from the University of the South Pacific Research Ethics Committee. All survey participants were thoroughly informed about the purpose of this research, which was detailed at the beginning of the questionnaire.

### *Sampling*

The research was conducted in two public sectors organisations, the Ministry of Education Heritage and Arts (MEHA) and the Ministry of Lands and Mineral Resources (MLMR), because of easier accessibility. A total of 205 questionnaires were distributed, and 114 were received, with a response rate of 56 per cent. Purposive sampling was used to select participants currently employed in the public sector (those holding non-managerial positions) based on the characteristics of demographic diversity. Questionnaires were hand-delivered to the participants during their working hours and collected after a week.

### *Measures*

The questionnaire was designed around a Diversity Management scale (independent variable) and five hypothesis scales (dependent variables). All the items in the scale were measured using Likert scale ratings of "1" as "Strongly Disagree", "2" as Disagree, "3" as Neutral, "4" as Agree and "5" as "Strongly Agree".

A three-item scale was adopted from Pitts (2009) to measure Diversity Management. A job satisfaction scale of two items and a workgroup performance scale of one item as adopted from Pitts's (2009) study. The workgroup performance scale was further modified by adding two questions, "I receive constant feedback on how I am doing in my job" and "I receive the training I need to perform my job effectively". The inclusiveness of the organisational culture scale was adopted from Ashikali and Groeneveld

(2015b). However, only five items were chosen because two statements on discrimination and intimidation were considered similar and combined into one statement: “I find the organisational policies to be fair and non-discriminatory”. The affective commitment scale had three items adopted from Ashikali and Groeneveld (2015b). The organisational commitment scale had three items adopted from Kundu and Mor (2016) and Magoshi and Chang (2009). Another question was added from the supported literature: “I strongly feel connected with the organisation’s vision, mission and goals” (Angel and Perry, 1981). The items were added to the scale to improve reliability, which was tested using Cronbach’s alpha analysis. Appendix 1 contains the questionnaire.

Table 1. Demographic Profile of Participants

<b>Characteristics</b>	<b>N (Frequency)</b>	<b>% (Percentage)</b>
<b>Ethnicity</b>		
iTaukei	51	45
Indo-Fijian	57	50
Others	6	5
<b>Gender</b>		
Male	45	39
Female	67	59
LGBTQI	2	2
<b>Age</b>		
20-29 years	49	43
30-39 years	39	34
40 years above	6	23
<b>Total</b>	<b>114</b>	<b>100</b>

In this study, out of 114 participants (59% of participants) were from MEHA, and 41% from MLMR.

### *Analysis*

SPSS v25 was used for descriptive analysis of data, while SPSS AMOS v22 was used to carry out SEM to perform hypotheses testing to support research and theory.

### **Results**

AMOS was employed in this research to test the selected relevant theories with confirmatory factor analysis, for which CB-SEM is more applicable (Hair et al., 2013) as it helps with the development of scales, exploratory and confirmatory

analyses, latent constructs' relative salience as well as evaluates causal relationships (Byrne, 2010).

Prior to analysis, for the data screening procedure, the dataset was checked for any missing values and outliers. While frequency tests using SPSS v25 of all variables showed no missing values, the boxplot results outlier test identified two outliers in the Affective Commitment scale. A thorough manual check of the two identified outliers showed data entry errors of 44 and 33 instead of 4 and 3. These were corrected.

For exploratory factor analysis (EFA), the Kaiser–Meyer–Olkin measure of sampling adequacy (KMO) and Bartlett's test of sphericity are the key assumptions. The KMO statistic should be  $>.50$ , while Bartlett's test of sphericity should be statistically significant at  $p < 0.05$  (Pallant, 2013). KMO (0.915) confirms the adequacy of this study's sample size. Bartlett's test was also significant, confirming the correlation matrix's suitability for factor analysis.

Furthermore, data were considered normal since skewness values were between -2 to +2 and kurtosis between -7 to +7 (Byrne, 2010; Hair et al., 2010). Principal component analysis (PCA) is the most common method for factor extraction. Rotation was carried out using the Varimax rotation method. All communalities were  $>0.40$  and were thus important for factor extraction.

All Variance Inflation Factor (VIF) scores were  $<10$ , ranging from 1.871 to 3.255, and tolerance (t)  $>0.1$  (Paruq et al., 2021), ranging from -0.635 to 4.581, thus multicollinearity was not an issue. Common method bias was calculated using Harman's single factor test, which was 46.99%, below the 50% threshold, confirming that the findings of this study are not affected by common method bias.

### *Reliability and validity*

Cronbach's alpha test was performed to confirm the reliability of the scales used in this study. The six scales have acceptable to good internal reliability, with Cronbach's alpha being 0.740 for Diversity Management (DM), 0.900 for Inclusiveness of Organizational Culture (IOC), 0.930 for Affective Commitment (AC), 0.864 for Organizational Commitment (OC), 0.748 for Job Satisfaction (JS) and 0.705 for Work Group Performance (JP); all  $>0.7$  threshold (Griethuijsen et al., 2015).

Convergent validity (average variance extracted-AVE) was confirmed, as almost all scales were within the acceptable range,  $>0.5$  (Hair et al., 2016), with 0.83 for AC, 0.68 for OCom, 0.61 for JS, and 0.74 for IOC, except for JP ( $0.47 < 0.5$ ). Because the convergent validity for the JP construct was  $<0.5$ , composite reliability was further computed for this construct. Composite reliability for JP is  $0.72 > 0.6$ ; thus, convergent validity for JP was also acceptable (Fornell and Larcker, 1981). Discriminant validity was confirmed for all constructs since the square root of AVE was  $<0.85$  for all scales except for the AC construct. Maximum shared variance (MSV) and average shared squared variance (ASV) were thus computed for this construct; both were less than AVE, 0.14 and 0.12, respectively; thus, discriminant validity was also confirmed for this construct. The table below presents these calculations.

Table 2. Convergent validity and Discriminant validity

			<b>Convergent validity</b>	<b>Discriminant validity</b>
<b>Indicator variables</b>	<b>Latent Variables</b>	<b>Standard Loadings</b>	<b>AVE</b>	<b>Sqrt of AVE</b>
AC1	AC	0.824		
AC2	AC	0.951		
AC3	AC	0.951	0.829	<b>0.910</b>
OCom1	OCom	0.812		
OCom2	OCom	0.943		
OCom3	OCom	0.696	0.678	0.823
JS1	JS	0.707		
JS2	JS	0.847	0.609	0.780
JP3	JP	0.742		
JP2	JP	0.699		
JP1	JP	0.596	<b>0.465</b>	0.681
IOC2	IOC	0.788		
IOC3	IOC	0.910		
IOC4	IOC	0.899		
IOC5	IOC	0.84	0.741	0.860

Table 3. Composite Reliability

Indicator Variables	Latent Variables	Standardised Loadings (SL)	Sum of SL	Sq of sum of SL (C)	C+M E	Composite Rel=C/(C+ME)
JP3	JP	0.742				
JP2	JP	0.699				
JP1	JP	0.596	2.037	4.149	5.754	0.72

Table 4. AVE, MSV and ASV

Factor 1: AC	Standardised Loadings	Shared Variance	CR	AVE	MSV	ASV
AC1	0.95	0.77	0.94	0.83	0.71	0.63
AC2	0.95	0.76				
AC3	0.83	0.84				

After the reliability and validity tests, an initial Confirmatory Factor Analysis (CFA) was carried out for the measurement model assessment for overall data. A few indicators were dropped because of lower standardised loadings. An acceptable model fit was then confirmed (CMIN/DF=1.739<3.0, NFI=0.902, IFI=0.956, CFI=0.955; PNFI=0.664, PCFI=0.703; RMSEA=0.08 (Schmitt 2011). The below Figure presents the measurement model.

#### *Structural equation model and hypothesised relationships*

Upon reliability and validity confirmations, SEM was created to carry out regression path analysis to test the hypothesised relationships. As per the recommendation of Hair et al. (2010) and Schmitt (2011), an appropriate fit was confirmed: (CMIN/DF=1.704<3.0, IFI=0.943, TLI=.931, CFI=0.943: all >0.9, PNFI=0.731, PCFI 0.789, both >0.5 and RMSEA=0.079<0.08). Figure 1 and Table 5 below present the overall SEM results.

Figure 1. Overall SEM

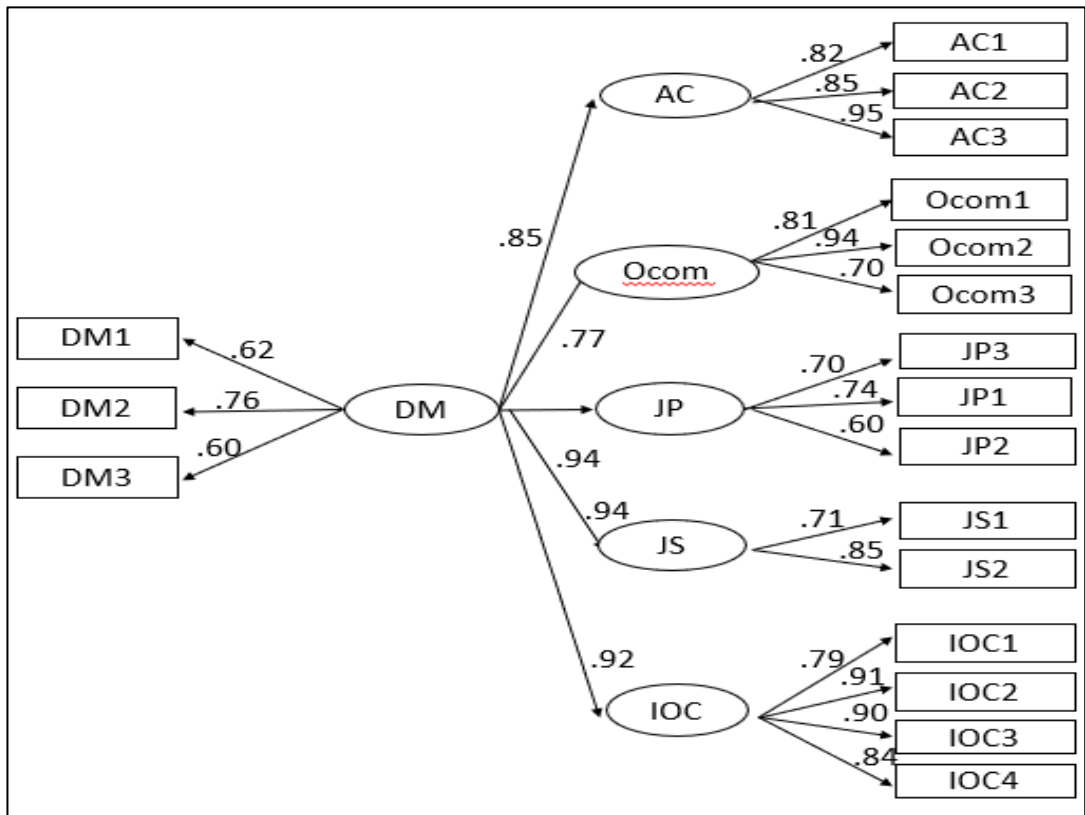

Table 5. Standardised loadings: (overall SEM)

Indicators	Description	Paths	Factors	Standardised Loadings	P
AC	Affective Commitment	<---	DM	.852	***
OCom	Organisational Commitment	<---	DM	.771	***
JP	Job Performance	<---	DM	.942	***
JS	Job Satisfaction	<---	DM	.937	***
IOC	Inclusive Organisational Culture	<---	DM	.919	***
DM1	Supervisors/team leaders in my work unit are committed to a workforce diversity which represents all segments of the society.	<---	DM	.624	***
DM2	Managers/supervisors/ team leaders work well with employees of different backgrounds.	<---	DM	.603	***
DM3	Policies and programs promote diversity in the workplace (for example, recruiting minorities and	<---	DM	.755	

Indicators	Description	Paths	Factors	Standardised Loadings	P
	women, training in awareness of diversity issues, and mentoring)				
AC1	I feel like part of the family in my organisation.	<---	AC	.824	***
AC2	My organisation has a great deal of personal meaning for me.	<---	AC	.951	***
AC3	I feel like a strong sense of belonging in my organisation.	<---	AC	.951	
OCom1	I am willing to put in extra effort to help this organisation be successful.	<---	OCom	.812	***
OCom2	I strongly feel connected with the organisation's vision, mission and goals.	<---	OCom	.943	
OCom3	I will take up any tasks given in order to continue working for this organisation	<---	OCom	.696	***
JP1	I believe the overall work done by my work group is of good quality.	<---	JP	.596	***
JP2	I receive constant feedback on how I am doing in my job.	<---	JP	.699	***
JP3	I receive the training I need to perform my job effectively.	<---	JP	.742	
JS1	I am very satisfied with my job.	<---	JS	.707	***
JS2	I am very satisfied with my organisation.	<---	JS	.847	
IOC2	I can openly discuss my opinion without fear of negative consequences.	<---	IOC	.788	***
IOC3	My organisation has a work environment where different ideas and perspectives are valued.	<---	IOC	.910	
IOC4	I find the organisational policies to be fair and non-discriminatory	<---	IOC	.899	***
IOC5	The decisions made by managers about employees are fair.	<---	IOC	.840	***

Multigroup analysis was then done for groups of gender and age. Table 6 presents the SEM, standardised loadings, critical ratios and p values for the male employees.



Table 6. Standardised Regression Weights: (Male employees - Default model)

Indicators	Description	Paths	Factors	Standardised Loadings	Estimate	Critical Ratio	P
AC	Affective Commitment	<---	DM	.898	1.299	5.384	***
OCom	Organisational Commitment	<---	DM	.557	.468	3.177	.001
JP	Job Performance	<---	DM	.908	.863	3.372	***
JS	Job Satisfaction	<---	DM	.839	1.086	4.532	***
IOC	Inclusive Organisational Culture	<---	DM	.952	1.254	5.377	***
DM1	Supervisors/team leaders in my work unit are committed to a workforce diversity which represents all segments of society.	<---	DM	.689	.937	4.294	***
DM2	Managers/supervisors/team leaders work well with employees of different backgrounds.	<---	DM	.670	1.104	4.181	***
DM3	Policies and programs promote diversity in the workplace (for example, recruiting minorities and women, training in awareness of diversity issues, and mentoring)	<---	DM	.685	1.000		
AC1	I feel like part of the family in my organisation.	<---	AC	.816	.803	8.987	***
AC2	My organisation has a great deal of personal meaning for me.	<---	AC	.930	.928	14.092	***
AC3	I feel like a strong sense of belonging in my organisation.	<---	AC	.984	1.000		
OCom1	I am willing to put in extra effort to help this organisation be successful.	<---	OCom	.920	1.494	7.074	***
OCom2	I strongly feel connected with the organisation's vision, mission and goals.	<---	OCom	.833	1.000		
OCom3	I will take up any tasks given in order to continue working for this organisation	<---	OCom	.805	1.596	6.226	***
JP1	I believe the overall work done by my work group is of good quality.	<---	JP	.810	1.073	3.802	***

Indicators	Description	Paths	Factors	Standardised Loadings	Estimate	Critical Ratio	P
JP2	I receive constant feedback on how I am doing in my job.	<---	JP	.763	1.277	3.683	***
JP3	I receive the training I need to perform my job effectively.	<---	JP	.572	1.000		
JS1	I am very satisfied with my job.	<---	JS	.569	.563	3.482	***
JS2	I am very satisfied with my organisation.	<---	JS	.870	1.000		
IOC2	I can openly discuss my opinion without fear of negative consequences.	<---	IOC	.712	.777	6.024	***
IOC3	My organisation has a work environment where different ideas and perspectives are valued.	<---	IOC	.928	1.000		
IOC4	I find the organisational policies to be fair and non-discriminatory	<---	IOC	.895	.910	9.769	***
IOC5	The decisions made by managers about employees are fair.	<---	IOC	.778	.855	7.185	***

\*\*\*p value is significant at 0.001 level

From the male public organisation employees' results, all hypotheses are supported ( $p < 0.05$ ). For the male employees, DM has the strongest positive influence on the inclusiveness of organisational culture (IOC) with a standardised coefficient of 0.952;  $p < 0.000$ , followed by workgroup performance (JP) with a standardised coefficient of 0.908;  $p < 0.000$ . The results show that DM also reported a strong positive impact on Job Satisfaction (JS) with a standardised coefficient of 0.839;  $p < 0.000$  as well as on Affective Commitment (AC) with a standardised coefficient of 0.898;  $p < 0.000$ . The weakest relationship was observed with organisational commitment (OCom), with a standardised coefficient of 0.557;  $p = 0.001$ . The male employees thus perceive that the DM by public sector organisations affect the inclusiveness of organisational culture (IOC) the most and OCom the least.

Table 7. Standardised Regression Weights: (Female employees - Default model)

Indicators	Description	Paths	Factors	Standardised Loadings	Estimate	Critical Ratio	P
AC	Affective Commitment	<---	DM	.813	1.005	6.634	***
OCom	Organisational Commitment	<---	DM	.804	0.995	6.973	***
JP	Job Performance	<---	DM	.951	1.205	6.374	***
JS	Job Satisfaction	<---	DM	.974	1.115	7.281	***
IOC	Inclusive Organisational Culture	<---	DM	.896	1.202	7.253	***
DM1	Supervisors/team leaders in my work unit are committed to a workforce diversity which represents all segments of society.	<---	DM	.615	.728	5.138	***
DM2	Managers/supervisors/team leaders work well with employees of different backgrounds.	<---	DM	.543	.619	4.468	***
DM3	Policies and programs promote diversity in the workplace (for example, recruiting minorities and women, training in awareness of diversity issues, and mentoring)	<---	DM	.773	1.000		
AC1	I feel like part of the family in my organisation.	<---	AC	.766	.854	9.167	***
AC2	My organisation has a great deal of personal meaning for me.	<---	AC	.957	1.014	14.654	***
AC3	I feel like a strong sense of belonging in my organisation.	<---	AC	.932	1.000		
OCom1	I am willing to put in extra effort to help this organisation be successful.	<---	OCom	.797	.877	9.638	***
OCom2	I strongly feel connected with the organisation's vision, mission and goals.	<---	OCom	.992	1.000		
OCom3	I will take up any tasks given in order to continue working for this organisation	<---	OCom	.659	.687	6.652	***

Indicators	Description	Paths	Factors	Standardised Loadings	Estimate	Critical Ratio	P
JP1	I believe the overall work done by my work group is of good quality.	<---	JP	.467	.357	3.680	***
JP2	I receive constant feedback on how I am doing in my job.	<---	JP	.673	.763	5.490	***
JP3	I receive training I need to perform my job effectively.	<---	JP	.779	1.000		
JS1	I am very satisfied with my job.	<---	JS	.764	.860	7.228	***
JS2	I am very satisfied with my organisation.	<---	JS	.850	1.000		
IOC2	I can openly discuss my opinion without fear of negative consequences	<---	IOC	.809	1.044	9.127	***
IOC3	My organisation has a work environment where different ideas and perspectives are valued.	<---	IOC	.912	1.000		
IOC4	I find the organisational policies to be fair and non-discriminatory	<---	IOC	.912	.971	12.036	***
IOC5	The decisions made by managers about employees are fair.	<---	IOC	.855	.971	10.459	***

\*\*\*p value is significant at 0.001 level

For the female public organisation employees, all five hypotheses are also supported, given significant p values. Unlike the male employees, however, for the female employees, DM has the strongest positive influence on job satisfaction (JS) with a standardised coefficient of 0.974;  $p < 0.000$ , followed by workgroup performance (JP) with a standardised coefficient of 0.951;  $p < 0.000$  and inclusiveness of organisational culture (IOC) with a standardised coefficient of 0.896;  $p < 0.000$ . The results show that DM also reported a strong positive impact on affective commitment (AC) with a standardised coefficient of 0.813;  $p < 0.000$  as well as on organisational commitment (OCom) with a standardised coefficient of 0.804;  $p < 0.000$ .

## Discussion

The findings of this study proved the assumption that the presence of diversity management efforts in public organisations in a male-dominated society demonstrates equity in opportunities and policies. This is reflected in female

employees' perception of high levels of their work outcomes. This study supports Kim, Lee and Kim's (2015) view that the presence of diversity management attenuates or removes gender differences in organisational commitment in male-dominated cultures. The finding of this study on organisational commitment is similar to Magoshi and Chang (2009) and Kim, Lee and Kim (2015). They report a positive effect of diversity management on both genders' commitment in Japan's and Korea's male-dominated cultures. This study also shows that diversity management has removed gender differences on other work outcomes of affective commitment, job satisfaction, work group performance and inclusiveness of organisational culture. The benefits of diversity management in Fiji's case may have been facilitated by changing political, cultural norms and leadership capabilities. The institutionalisation of diversity management via public sector reforms with the aim of effective public service delivery has pushed for wider acceptance of diversity management initiatives (open merit recruitment and training) by senior management. It has challenged gendered norms in Fiji's society by encouraging women to apply for job positions and their active participation in the workplace. The male-dominated orientation is likely alleviated through NPM reforms of diversity initiatives. Furthermore, research shows that with the political and cultural changes, there has been a shift towards a hybrid style of leadership adopted by Fijian cooperatives (business leaders) (Eti-Tofinga et al., 2017). Leaders are more inclusive in their approach to changing their leadership style based on context and legitimacy for their followers. Research also highlights leadership capabilities of Fiji's public sector organisations permanent secretaries as more strategic oriented, result oriented and fostering productive working relationships with a focus on valuing diversity (Andrews, 2019). These evolving leadership capabilities could be another factor which has allowed for diversity management initiatives to be effectively implemented by senior leaders despite the male-dominated cultural norms in society.

The findings on organisational commitment are similar to Kim, Lee and Kim (2015) and Magoshi and Chang's (2009) study in Korea's and Japan's male-dominated cultures. Diversity management has a positive impact on both genders' organisational commitment. The findings of Ashikali and Groeneveld's study (2015a) on affective commitment are similar, as diversity management positively impacts the affective commitment of male and female employees in the public sector. In addition, the findings of this study are in accordance with those of Pitts (2009) on job satisfaction and work group performance, Koç, Çavus and Saraçoğlu (2014) and Ordu (2016) on job

satisfaction and Ashikali and Groeneveld (2015b) on inclusive organisational culture. The positive work outcomes of both genders show that public sector organisations are taking good diversity management initiatives to satisfy the needs and concerns of their diverse employees. Therefore, implying an effective public service delivery and inclusivity in decision-making for diverse groups of people of both genders.

Female employees perceive diversity management efforts have a strong positive influence on all factors, with standardised coefficients ranging from 0.804 to 0.974. Interestingly, male employees perceive that the impact of diversity management efforts on organisational commitment is not as much as the impact on other factors. This is unlike female employees, who perceive a much higher impact of diversity management efforts on organisational commitment. This may be because females find diversity management efforts more encouraging and fairer compared to no diversity management efforts. A high level of commitment from employees demands family-friendly policies from the organisation (Osterman, 1995). There are government-regulated family-friendly policies of family care leave, maternity leave, paternity leave and MEHA teacher transfer policy. In being fair to females with diversity management efforts, organisations should be mindful of how such policies may affect the perception of male employees' commitment to the organisation.

### **Theoretical contribution**

This paper contributes to diversity management literature based on public employees' gender perceptions of their work outcomes in a male-dominated society. The application of representative bureaucracy theory, commitment management theory and social cognitive theory contribute to organisational development. The integration of these three theories brings about a robust argument for diversity management in the public sector while providing a culture of inclusion for both genders, this being the major theoretical contribution of this paper. The proposals of these theories are reinforced in the context of Fiji's public sector organisations. The confirmation of hypotheses in this research paves the way for future modifications and integration of theories in diversity management research. Effective diversity management policies and practices have a positive impact on both genders' work outcomes. This implies employee responsiveness in effective public service delivery and decision-making, as argued by the representative bureaucracy theory. When provided with diversity management strategies, employees reciprocated with

commitment, high job satisfaction, improved workgroup performance and feelings of inclusivity via positive psychological climate and self-efficacy beliefs. Public sector organisations should be persistent with diversity management initiatives to improve and enhance employees' work outcomes for greater organisational effectiveness and performance.

## **Practical Implications**

This study showed that diversity management is crucial for organisational effectiveness. There are several suggestions for organisations to yield the best outcomes from diversity management practices. First, a diversity strategy for public sector organisations is proposed. Any diversity strategy adopted should be aligned with the government's HR plan, such as the workforce business plan or the national development plan for the entire public sector. This will allow diversity management initiatives to be fully implemented, strengthened and realised at all levels in the entire public service (Ohemeng & McGrandle, 2015). Specifically, in male-dominated cultures, formal diversity management strategies will potentially reduce workplace discrimination targeted at women to a great extent. Second, diversity training programs that focus on creating awareness and dealing with demographic differences of gender should be provided to all public employees. Awareness training increases participants' self-awareness of diversity-related issues such as stereotyping (Cox & Blake, 1991). Employees should be consulted when designing such programs for wider acceptance and to dismantle gendered norms about women in society and the workplace. Team bonding exercises such as organisation retreats, small project teams and team-based workshops will help employees develop social bonds for greater team cohesiveness. It is proposed that family-friendly policies be strengthened to improve organisational commitment from employees while creating a positive climate for diversity. The provision of in-house childcare facilities, flexible working hours and awareness of existing family-friendly policies will improve organisational commitment. In doing so, organisations need to understand differences between the genders and administer policies that are favourable for male employees as well. Top leadership and management commitment are necessary to communicate the vision and fuel enthusiasm for diversity efforts through policies and practices (Verma, 2015). Managers should be persistent in their efforts to provide supportive mentoring opportunities to all employees specifically females to constantly boost their self-efficacy to sustain high levels of job satisfaction. To dismantle workplace discrimination and fully realise the benefits of diversity management at the workplace in male-

dominated cultures, effective implementation of such policies and practices is needed.

### **Limitations and future research directions**

The first limitation is the small sample size of the participants due to time and resource constraints. This limits the generalizability of research to other public sector organisations. Future research could include employees from other public organisations to increase the sample size and to better comprehend their perceptions of diversity management. In addition, mixed method or supplementary qualitative research is suggested to explore management's perceptions of diversity management. Including managers and supervisors from all levels and departments will provide a comprehensive view. This will provide a more credible understanding of the diversity management phenomenon in organisations, employee behaviour and their work outcomes. Future studies could also explore the impact of diversity management on other dependent variables, such as trust, employee turnover, and adaptability, to further explore the importance of diversity management.

### **Conclusion**

This study showed that both genders perceive positive effects of diversity management on their work outcomes without significant differences; males, however, perceived lower levels in organisational commitment. Diversity management strategies need to consider differences between both genders to improve organisational commitment for all employees. In a highly male-dominated context, diversity management in organisations plays a crucial role in dismantling gendered norms about females and brings about equity in policies and practices, thus improving work outcomes for both the employees and the organisation. With the NPM reforms of diversity initiatives and changing political, cultural and leadership norms, diversity management has been gradually implemented in public sector organisations. These factors have reduced the restrictions of society's gendered norms by giving women equal opportunities (career development, decision-making) in the workplace.

### **References**

Adusah-Kaikari, A. & Ohemeng, F. K. (2014). Representative bureaucracy in the public service? A critical analysis of the challenges confronting women in the civil service in Ghana. *International Journal of Public*



- Administration*, 9, 568-580.
- Alhejji, H., Garavan, T., Carbery, R., O'Brien, F., & McGuire, D. (2016). Diversity training programme outcomes: A systematic review. *Human Resource Development Quarterly*, 27, 95-149.
- Allen, N. J. & Meyer, J. P. (1991). A three-component conceptualisation of organisational commitment. *Human Resource Management Review*, 1(1), 61-89.
- Andrews, K. (2019). Leadership capabilities in Fiji's civil service: perspectives of senior officials. *Asia Pacific Journal of Public Administration*, 41(1), 48-55.
- Angel, H. L. & Perry, J. L. (1981). An empirical assessment of organisational commitment and organisational effectiveness. *Administrative Science Quarterly*, 26(1), 1-14.
- Ashikali, T. & Groeneveld, S. (2015a, March). Diversity management for all? An empirical analysis of diversity management outcomes across groups. *Personnel Review*, 757-780. <https://doi.org/10.1108/PR-10-2014-0216>
- Ashikali, T. & Groeneveld, S. (2015b). Diversity Management in Public Organizations and its Effect on Employees' Affective Commitment: The Role of Transformational Leadership and the Inclusiveness of the Organizational Culture. *Review of Public Personnel Administration*, 35(2), 146-168.
- Avery, D. R. & McKay, P. F. (2006). Target Practice: An organisational impression management approach to attracting minority and female job applicants. *Personnel Psychology*, 157-187.
- Bandura, A. (1997). *Self-efficacy: The Exercise of Control*. New York: W.H Freeman and Company.
- Byrne, B. M. (2010). Structural equation modelling with AMOS: Basic concepts, applications, and programming. New York: Routledge.
- Carless, S. (2004). Does psychological empowerment mediate the relationship between psychological climate and job satisfaction? *Journal of Business and Psychology*, 18(4), 405-425.
- Chattier, P. (2013). Does schooling and work empower women in Fiji? Or have gender inequalities persisted, and why? *Global Change, Peace & Security*, 25(1), 61-76.
- Chattier, P. (2015). Women in the House (of Parliament) in Fiji: What's Gender Got to Do With It? *The Round Table*, 104, 177-188.
- Cho, S. & Mor Barak, M. E. (2008). Understanding of Diversity and Inclusion

- in a Perceived Homogeneous Culture: A Study of Organizational Commitment and Job Performance Among Korean Employees. *Administration in Social Work*, 32(4).
- Choi, S. & Rainey, H. G. (2010). Managing Diversity in US Federal Agencies: Effects of Diversity and Diversity Management on Employee Perceptions of Organizational Performance. *Public Administration Review*, 1, 109-121.
- Cox, T. & Blake, S. (1991). Managing Cultural Diversity: Implications for Organizational Competitiveness. *The Executive*, 5(3), 45-56.
- Cox, T. (1994). *Cultural diversity in orgnaizations: Theory, research and practices*. San Francisco, CA: Berrett-Koehler Publishers.
- Deborah, J., Judith, P. & Shepherd, D. (2000). "Managing diversity" meets Aotearoa/New Zealand. *Personnel Review*, 29(3), 364-380.
- Doghan, M. A., Bhatti, M. A. & Juhari, A. S. (2019, May). Do Psychological Diversity Climate, HRM Practices, and Personality Traits(Big Five) Influence Multicultural Workforce Job Satisfaction and Performance? Current Scenario, Literature Gap, and Future Research Directions. *Research Article*,9(2).
- Eti-Tofinga, B., Douglas, H., & Singh, G. (2017). Influence of evolving culture on leadership: a study of Fijian cooperatives. *European Business Review*, 29(5), 534-550.
- Fiji Bureau of Statistics. (2020). *Public Sector*. Suva: Fiji Bureau of Statistics.
- Fiji Women's Rights Movement. (2016). *Sexual Harassment in the Workplace in Fiji - 2016 Follow-up Study*. Suva: FWRM.
- Fiji Women's Rights Movement. (2018). *Helping to balance the scales*. Suva: FWRM. Retrieved July 16, 2021, from <http://www.fwrn.org.fj/images/fwrn2017/balance/Balance-Dec-2018-PRINT-1.pdf>
- Fornell, C. and Larcker, D.F. (1981), "Evaluating Structural Equation Models with Unobservable Variables and Measurement Error", *Journal of Marketing Research*, Vol. 18 No. 1, pp.39-50.
- Ghasemi, M. (2014). The Relationship between Diversity Management and Organizational Commitment: Case Study of Employees of Telecommunications Corporation of Sistan and Baluchestan Province. *Indian Journal of Scientific Research(IJSCR)*, 3(1), 452-459.
- Gibson, S. K. (2004). Social Learning (Cognitive) Theory and Implications for Human Resource Development. *Advances in Developing Human Resource*, 6(193).

- Griethuijsen, R. A. L. F., Eijck, M. W., Haste, H., Brok, P. J., Skinner, N. C., Mansour, N., Gencer, A. S. & BouJaoude, S. (2015). Global Patterns in Students' Views of Science and Interest in Science. *Res Sci Educ* 45, 581–603.
- Hair, J., Black, W., Babin, B., Anderson, R. and Tatham, R. (2010), *Multivariate data analysis*, 7th ed., Pearson Prentice Hall, Upper Saddle River, NJ.
- Hair Jr J. F., Hult G. T., Ringle C. & Sarstedt M. (2016). *A primer on partial least squares structural equation modeling (PLS-SEM)*. Sage Publishers.
- Hair, J., Ringle, C., & Sarstedt, M. (2013). Partial Least Squares Structural Equation Modeling: Rigorous Applications, Better Results and Higher Acceptance. *Long Range Planning*, 46, 1-12.
- International Labour Organization. (2018). *World Employment and Social Outlook: Trends for Women 2018 - Global Snapshot*. Geneva: International Labour Office.
- International Labour Organisation (2019, August ) *International Labour Organisation*. ILO. Retrieved July 10, 2021, from [https://www.ilo.org/ifpdial/information-resources/national-labour-law-profiles/WCMS\\_158895/lang--en/index.htm](https://www.ilo.org/ifpdial/information-resources/national-labour-law-profiles/WCMS_158895/lang--en/index.htm)
- International Labour Organization. (2020, January 10). *Gender equality in the workplace remains elusive*. Retrieved July 16, 2021, from ILOSTAT: <https://ilostat.ilo.org/gender-equality-in-the-workplace-remains-elusive/>
- International Labour Organization. (2021). *Equality and discrimination in Pacific island countries*. Retrieved July 16, 2021, from International Labour Organization: <https://www.ilo.org/suva/areas-of-work/equality-and-discrimination/lang--en/index.htm#banner>
- Jin, M., Lee, J. & Lee, M. (2017). Does leadership matter in diversity management? Assessing the relative impact of diversity policy and inclusive leadership in the public sector. *The Leadership and Organizational Development Journal*, 38(2), 303-319.
- Kehoe, R. R. & Wright, P. M. (2013). The Impact of High-Performance Human Resource Practices on Employees' Attitudes and Behaviors. *Journal of Management*, 39(2), 366-391.
- Kim, H. K., Lee, U. H. & Kim, Y. H. (2015). The effect of workplace diversity management in a highly male-dominated culture. *Career Development International*, 20(3), 259-272.

- Kim, S. & Park, S. (2017). Diversity Management and Fairness in Public Organizations. *Public Organiz Rev*, 17, 179-193.
- Klarsfeld, A., Booyesen, L. A., Ng, E., Roper, I. & Tatli, A. (2014). *International Handbook on Diversity Management at Work, Country Perspectives on Diversity and Equal Treatment* (2nd ed.). Cheltenham: Edward Elgar.
- Koç, M., Çavus, M. F. & Saraçoğlu, T. (2014). Human Resource Management Practices, Job Satisfaction and Organizational Commitment. *International Journal of Academic Research in Business and Social Sciences*, 4(9), 178-190.
- Kundu, S. & Mor, A. (2016). Effect of Diversity Management on Employees Organisational Commitment: A Study of Indian Organisations. *Journal of Strategic Human Resource Management*, 5(1), 16-22.
- Long, N. E. (1952). Bureaucracy and Constitutionalism. *American Political Science Review*, 46, 808-818.
- Magoshi, E. & Chang, E. (2009). Diversity Management and the effects on employees' organisational commitment: Evidence from Japan and Korea. *Journal of World Business*, 44, 31-40. <https://doi.org/10.1016/j.jwb.2008.03.018>
- March, J. & Simon, H. (1958). *Organisations*. John Wiley & Sons Inc.
- Mousa, M., Massoud, H. K. & Ayoubi, R. M. (2020). Gender, diversity management, perceptions, workplace happiness and organisational citizenship behaviour. *Employee Relations: The International Journal*, 42(6), 1249-1269.
- Myung, J., Jaeyong, L. & MiYoung, L. (2017). Does Leadership Matter in Diversity Management? Assessing the relative impact of diversity policy and inclusive leadership in the public sector. *Leadership and Organizational Development Journal*, 38(2), 303-319.
- Naff, C. K. & Kellough, J. E. (2003). Ensuring Employment Equity: Are Federal Diversity Programs Making a Difference? *International Journal of Public Administration*, 26(12), 1307-1336.
- Naidu, V. (2013). *Fiji: the challenges and opportunities of diversity*. Minority Rights Group International.
- OECD. (2020). *Diversity at Work*. OECD. Retrieved July 17, 2021, from <https://www.oecd.org/els/diversity-at-work-policy-brief-2020.pdf>
- Ohemeng, F. & McGrandle, J. (2015). The Prospects for Managing Diversity in the Public Sector: The Case of the Ontario Public Service. *Public Organiz Rev*, 15, 487-507.
- Ordu, A. (2016). The effects of diversity management on job satisfaction and

- individual Performance of Teachers. *Education Research and Reviews*, 11(3), 105-112.
- Osterman, P. (1995, December). Work/Family Programs and the Employment Relationship. *Administrative Science Quarterly*, 40(4), 681-700.
- Pallant, J. (2013). SPSS Survival Manual. A step-by-step guide to data analysis using SPSS (4th edition). Allen & Unwin, Retrieved July 1, 2021, from [www.allenandunwin.com/spss](http://www.allenandunwin.com/spss)
- Parker, C. P., Baltes, B., Young, S., Huff, J., Altmann, R., Lacost, H. & Roberts, J. (2003). Relationships between psychological climate perceptions and work outcomes: a meta-analytic review. *Journal of sorganisational behavior*, 24(4), 389-416.
- Paruq, U., Arafat, Y., & Putra, A. Y. (2021). The influence of principal managerial and work motivation toward teacher performance. *JPGI (Jurnal Penelitian Guru Indonesia)*, 6(3), 632-640.
- Pitts, D. (2005). Diversity, representation and performance: Evidence about race and ethnicity in public organisations. *Journal of Public Administration Research and Theory*, 4, 615-631.
- Pitts, D. W. (2006, June 17). Implementation of Diversity Management Programs in Public Organizations: Lessons from Policy Implementation Research. *Andrew Young School of Policy Studies Research Paper Series*, pp. 1-23. Pitts, D. W. (2009). Diversity Management, job satisfaction, and performance: evidence from US Federal agencies. *Public Administration Review*, 69(2), 328-38.
- Pitts, D. W., Hicklin, A. K., Hawes, D. P., & Melton, E. (2010). What Drives the Implementation of Diversity Management Programs? Evidence from Public Organizations. *Journal of Public Administration Research and Theory*, 20, 867-886.
- Pless, N. M. & Maak, T. (2004). Building an Inclusive Diversity Culture: Principles, Processes and Practice. *Journal of Business Ethics*, 54(2), 129-147.
- Rice, M. F. (2010). *Diversity and Public Administration Theory, Issues and Perspectives* (2nd ed.). New York, USA: Routledge.
- Romanenko, A. (2012). *Cultural Diversity Management in Organizations: The Role of Psychological Variables in Diversity Initiatives*. Hamburg.
- Schmitt, T. A. (2011). Current methodological considerations in exploratory and confirmatory factor analysis. *Journal of Psychoeducational Assessment*, 29(4), 304-321.
- Soni, V. (2000, September). A Twenty-First-Century Reception for Diversity in

the Public Sector: A Case Study. *Public Administration Review*, 60(5), 395-408.

Stone, R. J. (2017). *Human Resource Management* (9th ed.). Milton Qld: John Wiley & Sons.

Tabachnick, B.G. & Fidell, L.S. (2007). *Using multivariate statistics*, University of Chicago Press, Chicago.

Thomas, R. R. (1990, March-April). From Affirmative Action to Affirming Diversity. *Harvard Business Review*, 68(2), 107-117.

Verma, A. (2015). Valuing Diversity: Strategies and Implications for Organisational Success. *Prestige International Journal of Management and Research*, 7/8(1/2), 31-38.

Wrench, J. (2007). *Diversity Management and Discrimination: Immigrants and Ethnic Minorities in the UK*. New York: Routledge.

Yadav, S., & Usha, L. (2020). Diversity management: a systematic review. *Equality, Diversity and Inclusion: An International Journal*. doi:10.1108/EDI-07-2019-0197.

## Appendix 1

Variable	Statement	Mean	Standard deviation
<b>Diversity Management (Independent Variable)</b>	1.Supervisors/team leaders in my work unit are committed to a workforce diversity which represents all segments of the society.	4.16	0.76
	2.Policies and programs promote diversity in the workplace (for example, recruiting minorities and women, training in awareness of diversity issues, mentoring).	3.99	0.81
	3.Managers/supervisors/ team leaders work well with employees of different backgrounds.	3.95	0.86
<b>Inclusiveness of Organizational Culture</b>	1.Where I work, I am treated with respect and dignity.	4.11	0.73
	2.I can openly discuss my opinion without fear of negative consequences.	.67	1.02
	3.My organisation has a work environment where different ideas and perspectives are valued.	3.85	0.92
	4.I find the organisational policies to be fair and non-discriminatory.	3.85	0.86
	5.The decisions made by managers about employees are fair.	3.59	0.96
<b>Affective Commitment</b>	1.I feel like part of the family in my organisation.	3.90	0.89
	2.My organisation has a great deal of personal meaning for me.	4.42	4.71
	3.I feel like a strong sense of belonging in my organisation.	4.06	2.87
<b>Organisational Commitment</b>	1.I am willing to put in extra effort to help this organisation be successful.	4.29	0.85
	2.I strongly feel connected with the organisation’s vision, mission and goals.	4.21	4.75
	3.I will take up any tasks given in order to continue working for this organisation.	4.04	0.87
<b>Job Satisfaction</b>	1.I am very satisfied with my job.	4.04	0.79
	2.I am very satisfied with my organisation.	3.85	0.85
<b>Work Group Performance</b>	1.I believe the overall work done by my work group is of good quality.	4.28	0.67
	2.I receive constant feedback on how I am doing in my job.	3.82	0.91
	3.I receive training I need to perform my job effectively.	3.68	1.08