

Corrosion Behaviour of Sinter Forged Aluminium Composites during Hot Deformation

S. Narayan^{a, *}

A. Rajeshkannan^b

RN. Deo^c

*** Corresponding Author**

^aMr. SUMESH NARAYAN

Assistant Lecturer, Mechanical Engineering,
School of Engineering and Physics,
Faculty of Science, Technology & Environment,
The University of the South Pacific, Laucala Campus,
PO Box 1168, Suva, FIJI.
Off. No. +679 3232034,
Fax No. +679 3231538,
Email: narayan_su@usp.ac.fj

Co-Author

^bDr. ANANTHANARAYANAN RAJESHKANNAN

Senior Lecturer, Mechanical Engineering,
School of Engineering and Physics,
Faculty of Science, Technology & Environment,
The University of the South Pacific, Laucala Campus,
PO Box 1168, Suva, FIJI.
Email: ananthananarayanan_r@usp.ac.fj

Co-Author

^bDr. RAVIN N DEO

Lecturer, Physics,
School of Engineering and Physics,
Faculty of Science, Technology & Environment,
The University of the South Pacific, Laucala Campus,
PO Box 1168, Suva, FIJI.
Email: deo_ra@usp.ac.fj

Abstract

A galvanostatic pulse technique was used to determine corrosion behavior of sinter-forged aluminium composites. Specimens were prepared using powder metallurgy (P/M) manufacturing techniques, with two different initial relative density and various carbide reinforcements such as titanium carbide (TiC), molybdenum carbide (Mo_2C), iron carbide (Fe_3C) and tungsten carbide (WC). The specimens were machined and molded in a thermo-plastic material so that a surface area of 1 cm^2 is exposed in a solution of 3.5wt% water solution of NaCl during the corrosion test. The corrosion behavior of the sinter-forged aluminium composites were studied alongside microstructure studies to expose corrosion dynamics and presented in this report.

Keywords: Corrosion; Galvanostatic; Aluminium composite; Powder metallurgy

1. Introduction

Carbide reinforced aluminium metal matrix composites are widely used in high strength industrial application due to low specific density, good wear resistance and low thermal expansion coefficient. SiC reinforced aluminium composites [1-2], TiC reinforced aluminium composites [3] and WC reinforced aluminium composites [4] have shown improved properties in aluminium metal matrix composites such as hardness, tool wear in turning, improvement in wear resistance and reduced corrosion rate. The presence of pores in the P/M parts especially open ones has significant effect on the corrosion resistance of sinter-forged aluminium composites. Wear and corrosion are the main reasons of P/M products failure in industry and these limit its application to corrosive and wear free environments. Solving these wear and corrosion problems will enhance the potential use of P/M parts for many industrial applications [5, 6].

Jinsun et al. [7] presented improved resistance of high strength Mg-Al-Mn-Ca magnesium alloy made by P/M process. They found that the SAWP process greatly improved the corrosion resistance due to dispersion of intermetallic phase. An emersion test method was used for the corrosion study. Dobrzanski et al. [8] conducted corrosion test using the measurement system consisting of the PG P-21 potentiostat working with the radiometer Copenhagen voltmeter 1 software. The corrosion behavior of varying composites was varying as well as the pitting amount and place on the exposed surface. A conventional electrochemical potentio-dynamics test was used by Marchiori et al. [9] in both cathode configuration and anode configuration to evaluate corrosion of plasma sintered unalloyed iron. Neubert et al. [10] studied mechanical properties and corrosion behavior of Al-Sc-Zr alloy prepared by P/M and reported the corrosion resistance and mechanical properties of Al-Sc-Zr is better than AA6061-T6 Al alloy. This was due to phase precipitation of Al₃ (Sc, Zr) particles during hot extrusion. Again they have used immersion test for 6 hours to determine the corrosion rate. Mamatha et al. [11] presented corrosion behavior of aluminium metal matrix composites reinforced with SiC particulates in HCl solution using weight loss method for 96 hours. The effect of varying SiC particulates in the aluminium composites on corrosion rate is evident. The corrosion resistance of iron P/M parts can be improved by surface treatment, nickel plating, coating, cathodic and anodic protection [12-13]. Steam treatment of sintered ferrous parts at 500°C improves the hardness, wear and corrosion properties on the exposed surface due to the formation of thin Fe₃O₄ layer on the

exposed surface [14-15]. The effect of WC content on the microstructure and corrosion behavior of Ti (C, N) based cermets in nitric acid solution was studied by Chenghong et al. [16]. It was observed that WC is more easily oxidized and dissolved in nitric acid solution compared to Ti (C, N), hence, the corrosion rate of cermets increases and the corrosion resistance of Ti (C, N) based cermets decreases with increasing WC content.

The standard technique used for evaluating corrosion tests of wrought materials as well as P/M parts is immersion weight loss method [17-19]. It is noted that immersion weight loss method is a standard technique to analyze corrosion behavior for any material produced via and manufacturing route. Further, some of the immersion solutions used by several researchers are 3.5wt% NaCl solution, 1 M HCl solution, 9wt% HNO₃ solution, 0.5 M KNO₃ solution; however, the use of immersion solution is consistent throughout the whole experiment [20-22]. There are many non-destructive techniques (NDT) used such as linear polarization resistance (LPR) method [23], galvanostatic pulse technique [24], potentiodynamic polarization test [7] and electrochemical impedance spectroscopy [25].

Currently no electrochemical process is well defined to measure the corrosion dynamics of aluminium metal matrix composites. Birbilis et al. [26] presented the problems encountered whilst using LPR method to study steel corrosion in concrete samples. They introduced a new technique to overcome problems encountered by other electrochemical process; the galvanostatic pulse technique. In this technique short galvanostatic pulse is used moving away from other technique using longer pulses with greater error [27]. Deo et al. [24] has successfully used this galvanostatic pulse technique successfully to study metal corrosion in different soils.

Based on the published literature, there is less information about the corrosion behavior of aluminium metal matrix composite with the effect of WC, Mo₂C and Fe₃C reinforcements. In the present study a galvanostatic pulse technique is used to evaluate the corrosion behavior of several aluminium metal matrix composites such as Al₁₁TiC, Al₂TiC, Al₃TiC, Al₄TiC, Al₂Fe₃C, Al₄Fe₃C, Al₂Mo₂C, Al₄Mo₂C, Al₂WC and Al₄WC. Al₁₁TiC represents 99% by weight of aluminium and 1% by weight of titanium carbide in final material. Similarly, Al₄TiC composite composes of 96% by weight aluminium and 4% by weight of TiC. Further, the effect of initial porosity levels in aforementioned

composites on corrosion resistance was also investigated and presented in this paper. A very similar method was used by Jinsun et al. [7] to study the corrosion behavior of magnesium alloy made by rapid solidification powder metallurgy process. They have used a typical three electrode cell with a saturated Ag/AgCl reference, Pt counter and the specimen as the working electrode and same is used in our research work.

2. Aluminium composite/NaCl solution interface

An interface is formed when the aluminium composite comes in contact with the 3.5% NaCl water solution. This interface can be modelled by an equivalent circuit called the Randle's circuit. The circuit reassembles $R_p C_{dl}$ parallel arrangement in series with NaCl solution resistance, R_Ω , whereby R_p is the polarization resistance and C_{dl} is the double layer capacitance shown in Fig. 1.a. The capacitance associated with the aluminium composite will vary depending on the reinforcements present in the composites. The double layer capacitance is non-ideal due to the β -parameter. β -parameter is an indicator of dispersion characteristics. It can be used to illustrate how the surface is taking part in the corrosion process. When $\beta = 1$, it indicates ideal uniform corrosion and C_{dl} is an ideal capacitor. When $\beta < 1$, it indicates localized corrosion and C_{dl} is a non-ideal capacitor.

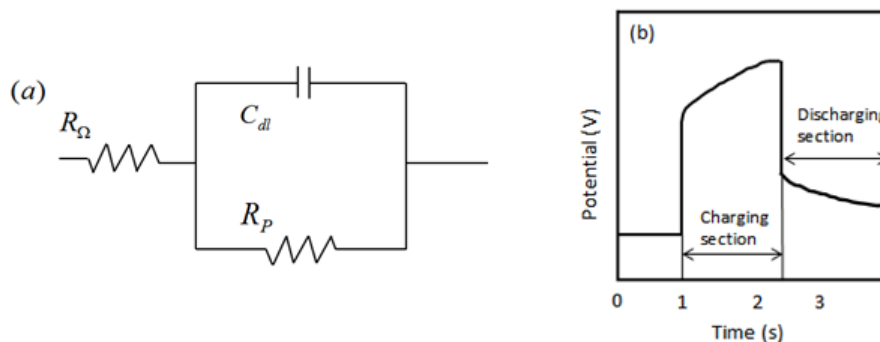

Figure 1: (a) Equivalent circuit diagram of the metal matrix composites/NaCl solution interface, (b) the Randle's type circuit used to model the interfacial response in this study.

3. Experimental Details

3.1 Specimen preparation

The materials used in the current investigation are aluminium powder of 150 μm and titanium carbide, tungsten carbide, molybdenum carbide and iron carbide, of 50 μm . All powders used in the present investigation had purity levels of 99.7%.

The required amount of powders was mixed to obtain the aforementioned aluminium carbide composites using planetary ball milling machine. The ball mill was run for 2 hours at 200 rpm to get a homogenized mixture. The apparent density was continuously measured to ensure uniform distribution of the reinforcement particles in the matrix.

The powders corresponding to cylindrical specimens with diameter of 24 mm and height of 10 mm were compacted in a pressure range of 139 MPa to 159 MPa (hydraulic press) to obtain relative density of 0.86 ± 0.01 and 0.82 ± 0.01 . The specimens were coated with Al_2O_3 mixed with acetone to avoid oxidation during the sintering process. The specimens were left for atmospheric drying for a period of 24 hours.

Then the specimens were sintered in an electric muffle furnace at 220°C for 30 minutes and then at 594°C for an additional period of 60 minutes. Each specimen was compressively deformed at a temperature of 594°C to two different height strains. Finally the specimens were left for atmospheric cooling.

3.2 Solution Preparation

3.5% NaCl was prepared using analytical grade reagent and distilled water. Each specimen was immersed in 500 mls NaCl solution separately such that the ratio of exposed specimen surface area (cm^2) to volume of the NaCl solution (ml) was about 1:500.

3.3 Microstructure

The specimens for microstructure characterization were cut at the center with the observation plane parallel to the compression direction. The microstructures were examined using an optical

microscope. The specimens were ground with 1200 grit emery and polished with 9 microns diamond paste, then with 3 microns diamond paste and finally with colloidal silica. Then the specimens were cleaned with distilled water and absolute ethanol and dried with warm flowing air. These specimens were then etched with Keller's reagent. These were then cleaned with distilled water then ethanol and dried with warm flowing air before microstructure examination.

To study the corrosion behavior at the initial stage, another set of specimens were ground with 1200 grit emery and polished with 9 microns diamond paste, then with 3 microns diamond paste and finally with colloidal silica. These specimens were then immersed in the 3.5% NaCl water solution for 4 hours and the surface was observed with an optical microscope. The specimens were cleaned with distilled water, then with absolute ethanol and dried with warm flowing air.

3.4 Electrochemical measurement

A classical three electrode configuration was used with an Ag/AgCl reference electrode, platinum as counter electrode and the specimen as working electrode. All the specimens were machined to form cylinder of diameter of 1.13 cm. The specimens were then molded in a thermoplastic material to only expose a surface area of 1 cm². The exposed surface of the specimens for the test were ground using 1200 grit emery paper and cleaned with distilled water and absolute ethanol. A 2 mm hole was made into the thermoplastic material and a copper wire was inserted to just touch the specimen to allow galvanostatic pulse current flow. The hole was sealed with adhesive to hold the copper wire in place and to avoid the solution from entering. It was ensured that the exposed surface is not damaged. The Eco-chemie microAUTOLAB III potentiostat/galvanostat together with the General Purpose Electrochemical Software was used to supply short (1s) galvanostatic pulse and the resulting potential-time response was recorded internally by this set-up. The measurements were taken after 2 hours of immersion in 3.5% NaCl solution using a purpose-built inversion program. The counter and reference electrode were secured properly allowing contact with the solution. The depth of the immersion was kept constant. A potential of 1.5 V was supplied between the working and counter electrode for all the measurements. The potential circuit data's were then used to plot the charging and discharging curves along with the curve-fitting techniques to extract the corrosion related parameters. A purpose-built inversion program was also used for this analysis. The following parameters were

obtained such as corrosion potential (E_{corr}), β -parameter, polarization resistance (R_p) double layer capacitance (C_{dl}) and corrosion current density (I_{corr}) using the software program. A schematic of the experimental setup is given in Figure 2.

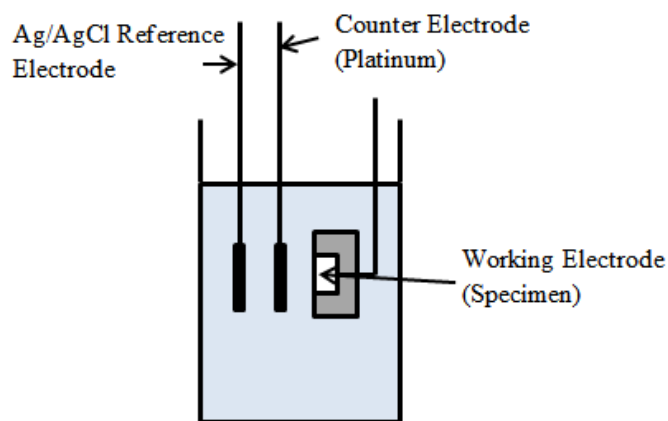

Figure 2: Illustration of the electrochemical setup in this study.

4. Results and Discussion

4.1 Microstructure

To study the corrosion behavior at the initial stage, all specimens after the standard preparation technique as discussed in section 3.3 of this paper were immersed in 3.5% NaCl water solution for 4 hours and the surface was observed with an optical microscope. The specimens were cleaned with distilled water, then with absolute ethanol and dried with warm flowing air before microstructure viewing. Figure 3 gives the microstructural view of TiC reinforced aluminium and Figure 4 gives the micrographs of WC, Fe₃C and Mo₂C reinforced aluminium metal matrix composites. Apart from the varying carbide and varying carbide concentrations, initial relative density and final height strain is varied. A low height strain here is referred to as low deformed specimen and a higher height strain is referred to as a highly deformed specimen. Quantifying the corrosion performance in Figures 3 and 4 were by visual inspection of the specimens and micrographs. Generally it was observed in most composites that lower initial relative density specimens showed poor materials resistance to corrosion. Further, low deformed specimens also showed poor materials resistance to corrosion. Specimens of 0.86 initial relative density and highly deformed specimens showed lower corrosion when compared to lower initial relative density and low deformed specimens. The presence of pores may act as the influencing factor here and lower initial relative density and low deformed specimens has higher

number of pores present in the bulk material promoting corrosion. It is seen from the microstructures that corrosion is higher around the pores and also around the carbide reinforcement particles. The chemical reaction for corrosion is enhanced at the interface boundaries of two different materials, that is, respective carbides and aluminium. Further, from Figure 3 it can be seen that when the TiC content is increased in the specimens the surface corrosion is reduced significantly, however, spot/localized corrosion is seen and is mainly around the reinforced particles. When the TiC particles are low the corrosion activity is mainly concentrated on the whole surface area. However, as the TiC particles increase the number of weaker interface boundaries is higher, between reinforced particle and aluminium particles, and the corrosion activity shifts to these weaker interface boundaries, promoting spot/localized corrosion. Also, pitting corrosion is enhanced in the highly deformed specimens as the TiC particles increases in the specimens. This is due to the surface variation due to presence of carbide reinforcements in composites can promote increased pitting corrosion.

From Figure 4 it can be stated that Mo₂C reinforced aluminium composites showed highest corrosion irrespective of initial relative density, percentage carbide concentrations, or high or low deformation of the specimen compared to other composites. Extensive pitting corrosion is shown by these specimens. After Mo₂C reinforced aluminium composites, TiC reinforced aluminium composites showed poor resistance to corrosion. Further, WC reinforced aluminium composite and Fe₃C reinforced aluminium composite showed better material resistance to corrosion when compared to Mo₂C and TiC reinforced aluminium composites. It can be concretely noted that Mo₂C reinforced composites prepared by primary powder metallurgy manufacturing process has very poor material resistance to corrosion. Hence, parts prepared from this combination and process needs to be well protected to avoid corrosion in actual application. Pitting corrosion starts with the formation of pits. Pit initiation starts with the absorption of Cl⁻ ions and its chemical reaction with the oxide film [28]. This phenomenon is high in Mo₂C reinforced aluminium composites. Thus many corrosion pits exists damaging the hard particle bonds. This will lead to the falling of unsupported hard phase particles from the surface of the specimen promoting rapid corrosion.

Further, it appears that Mo₂C composites have uniform attack (Fig 4.) on the surface whereas some of the other composites show localized attack. Localized attack will have lower loss of material giving

indication that it has higher resistance. However, localized attacks in composite materials are more detrimental for material performance. It is noted that either of the corrosion type, localized pitting or uniform surface corrosion will lead to failures and appropriate measures need to be taken to prevent such failures. For instance use of paints or metallic coatings, use of thicker materials, use of cathodic or anodic protection, controlling pH, chloride concentrations and proper selection of materials with known resistance to the service environment.

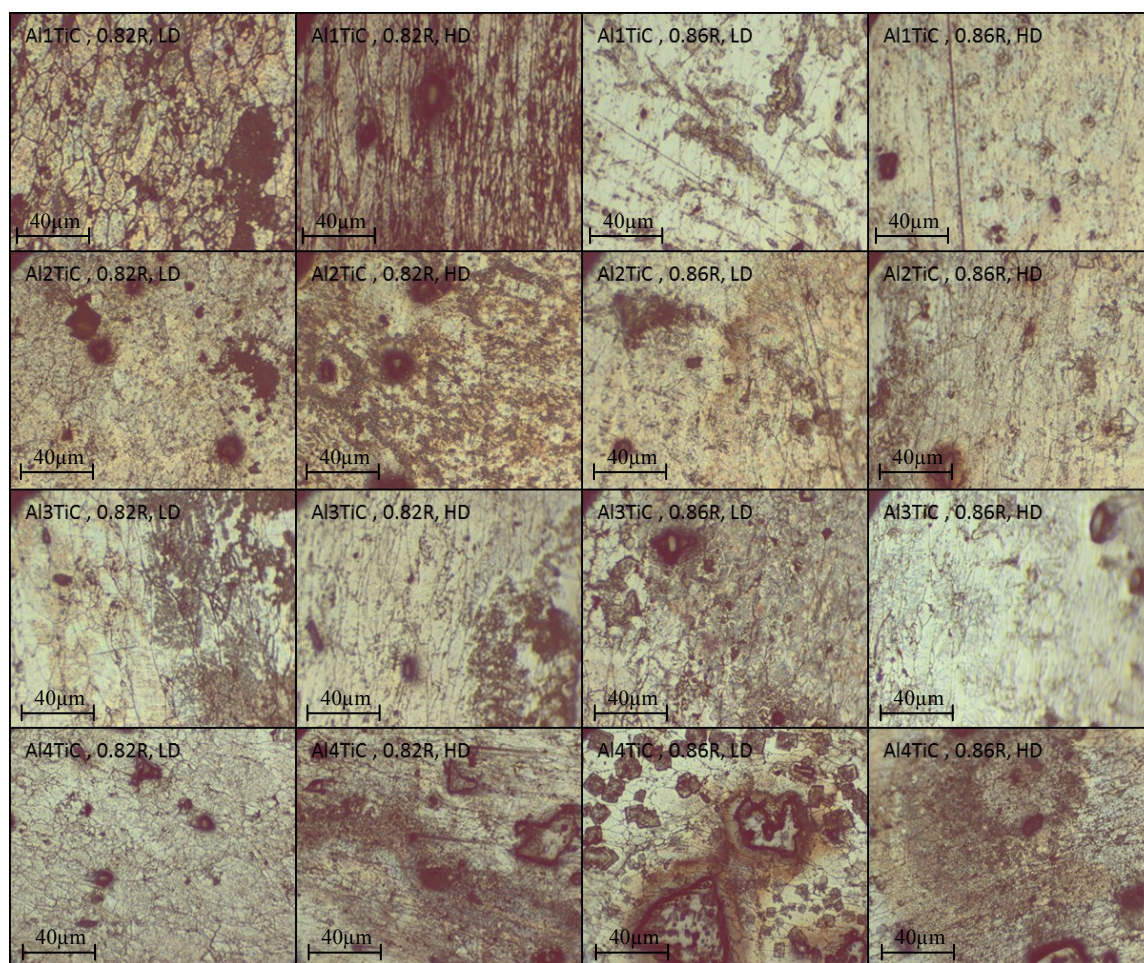

Figure 3: Micrographs of P/M TiC reinforced aluminium composites after immersion of 4 hours in 3.5%NaCl.

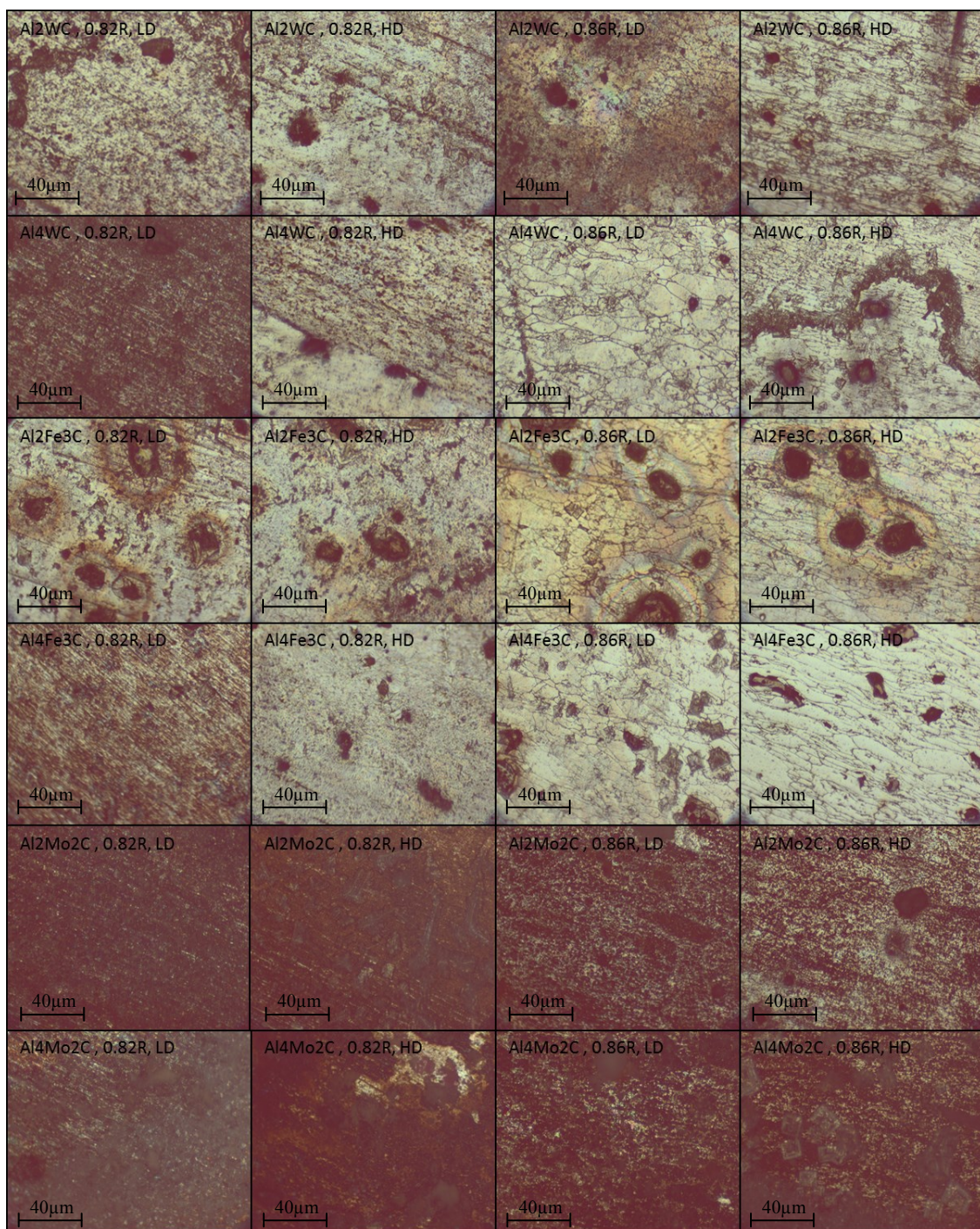

Figure 4: Micrographs of P/M WC, Fe₃C, Mo₂C reinforced aluminium composites after immersion of 4 hours in 3.5%NaCl.

4.2. Electrochemical measurements

4.2.1. The galvanostatic pulse technique

Results from short galvanostatic pulse measurements for different carbide reinforced aluminium are described here. Measurements were conducted at 2 hours after immersion in 3.5% NaCl water solution. The galvanostatic pulse technique measures the following parameters, polarization resistance, R_p , double layer capacitance, C_{dl} , beta parameter, β , and corrosion potential, E_{corr} . The following parameters can be successfully used to access the corrosion behavior of the metals and calculate the corrosion rate. A simple electric circuit was implemented and the potential time response was measured after application of a short (1s) galvanostatic pulse. The details of this circuit are discussed in Deo [29]. A typical potential time response measured in this work is shown in Figure 5. It has two potential-time response period, first is the charging curve and the other is the discharging curve. The charging curve is modelled by a Randle's type circuit shown in Fig. 1. a.

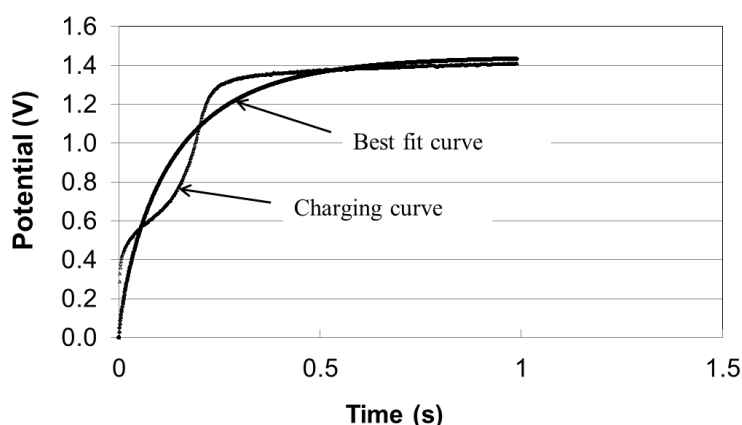

Figure 5: Potential time response of AlTiC, charging curve with best fit curve.

The corrosion related parameters (β , C_{dl} , R_p , E_{corr}) and R_{Ω} can be determined either by analyzing the charging curve or the discharging curve. A purpose-built inversion program is used for the measurements and analysis of results for this work and the details of the program is discussed elsewhere [30]. An excellent feature of the purpose-built inversion program is that the corrosion parameters can be determined by just analyzing the charging curve without the need of the discharging curve. On the other hand, if discharging curve is used to obtain the results then the charging curve needs to be analyzed first as the discharging curve analysis requires some input from the charging curve. Hence, as we just need the corrosion parameters (β , C_{dl} , R_p , E_{corr}) only the

charging curve is used for this work, the best curve fitting techniques is only applied to the charging curve using the purpose-built program with error bars.

4.2.2. Inter-relationship of polarization resistance and double layer capacitance

An increase in polarization resistance, R_p , values and a decrease in double layer capacitance values, C_{dl} , indicate an increase in materials resistance to corrosion. Similar method and analysis is discussed by Birbilis et al. [30] to evaluate corrosion behavior of reinforced steels in concrete. Further, as the polarization resistance, R_p , increases the corrosion current decreases indication low corrosion. A higher C_{dl} value indicates greater ability to store electric charge by the working electrode. This will create higher corrosion density indicating increased corrosion. It is noted that the distance between the reference electrode and the working electrode for all experimental work in this research is kept constant. Further, the test solution is also kept constant for all experimental works. Hence the R_p and C_{dl} values only depends on the variables tested in this research work which are carbide concentrations, height strain and initial relative density. Figure 6 gives the variation of C_{dl} against R_p . A strong inverse relationship between R_p and C_{dl} in log-log plot is depicted from Figure 6. Hence, R_p and C_{dl} corrosion parameters can be effectively used to study the corrosion behavior. This galvanostatic pulse corrosion parameters, β , C_{dl} , R_p , is effectively used to study reinforced steel corrosion in concrete slabs [26-30]. The authors have effectively utilized β , C_{dl} , R_p parameters to study corrosion behavior.

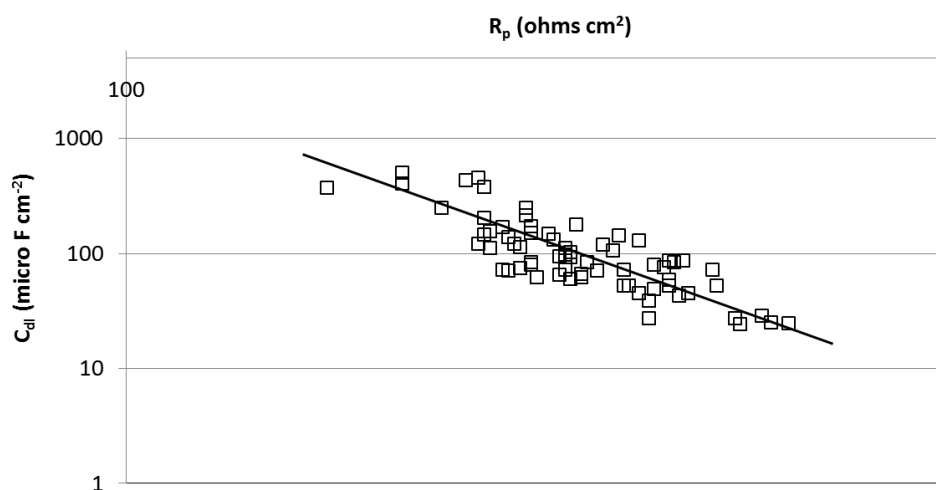

Figure 6: Variation between polarization resistance and double layer capacitance for different composites measured at 2 hours of immersion.

4.2.3. Galvanostatic pulse measurements

Figure 7 shows the variation of R_p and C_{dl} for the respective carbide reinforced aluminium tested in this research work. It can be seen (Fig. 7 (a and c)) that R_p is found to be higher in Al₂Fe₃C followed by Al₂WC, Al₂TiC and lowest for Al₂Mo₂C. At the same time C_{dl} is found to be higher in Al₂Mo₂C and Al₂TiC and lower in Al₂WC and Al₂Fe₃C. Al₂Fe₃C and Al₂WC showed greater material resistance to corrosion as Al₂TiC and Al₂Mo₂C showed poor material resistance to corrosion. When the carbide concentrations in the aluminium composites were increased from 2% to 4%, the following corrosion behavior is observed. Al₄Mo₂C and Al₄TiC showed lower R_p values compared to other composites (Fig. 7 (b)). The C_{dl} values seen in Figure 7(d) are inversely proportional to the R_p values seen in Figure 7(b). This indicates that the corrosion is higher in Al₄Mo₂C composite and lowest in Al₄Fe₃C composite. Same can be seen and verified in the optical micrographs given in Figures 3 and 4. The R_p and C_{dl} values are in good agreement with the micrographs obtained and hence, can be concretely stated that this corrosion analysis technique can be effectively used for powder metallurgy parts. Further, corrosion in metals usually starts at the interface boundaries and corrosion activity is promoted for powder metallurgy material due to the presence of pores. The pores present allow high pitting corrosion or localized corrosion. A decrease corrosion resistance in the composites is believed to be due to the possible microgalvanic coupling between the reinforced particles or pores and Al particles. Anaee [31] showed that the effect of WC weight ratio on the corrosion behavior of the composites in 0.1N NaOH solution was not consistent for the different weight percent of reinforcement (1, 2 and 3 wt%) used in developing the Al–Si–Cu based composites. Further, Guangbiao et al. [32] reported the corrosion resistance of Ti(C,N)-based cermets decreases with the increase of Mo₂C content. The Ti(C,N) grain skeleton is observed after the binder Ni is corroded off. Moreover, the corrosion was more serious with the increase of Mo₂C volume fraction in inner rim.

Further, from Figure 7 (e), it is noted that the R_p values remain almost constant even though the content of TiC in aluminium matrix is increased from 1% to 4% except for few cases where R_p values are higher indicating low corrosion in these specimens. Al₃TiC specimens showed lower C_{dl} (Figure 7 (f)) and slightly better R_p when compared to Al₁TiC, Al₂TiC and Al₄TiC. The micrographs also indicate the same that Al₃TiC showed better resistance to corrosion when compared to Al₁TiC and Al₂TiC. Similar results were presented by Murthy and Singh [33], however, a stir casting technique

was employed to produce the composites. They showed that the polarization resistance increases with the addition of TiC particulates. The observed increase in corrosion resistance of TiC particulate reinforced composites is attributed to excellent bond integrity of TiC particulates with aluminium and possible electrochemical decoupling between TiC particles and Al matrix alloy.

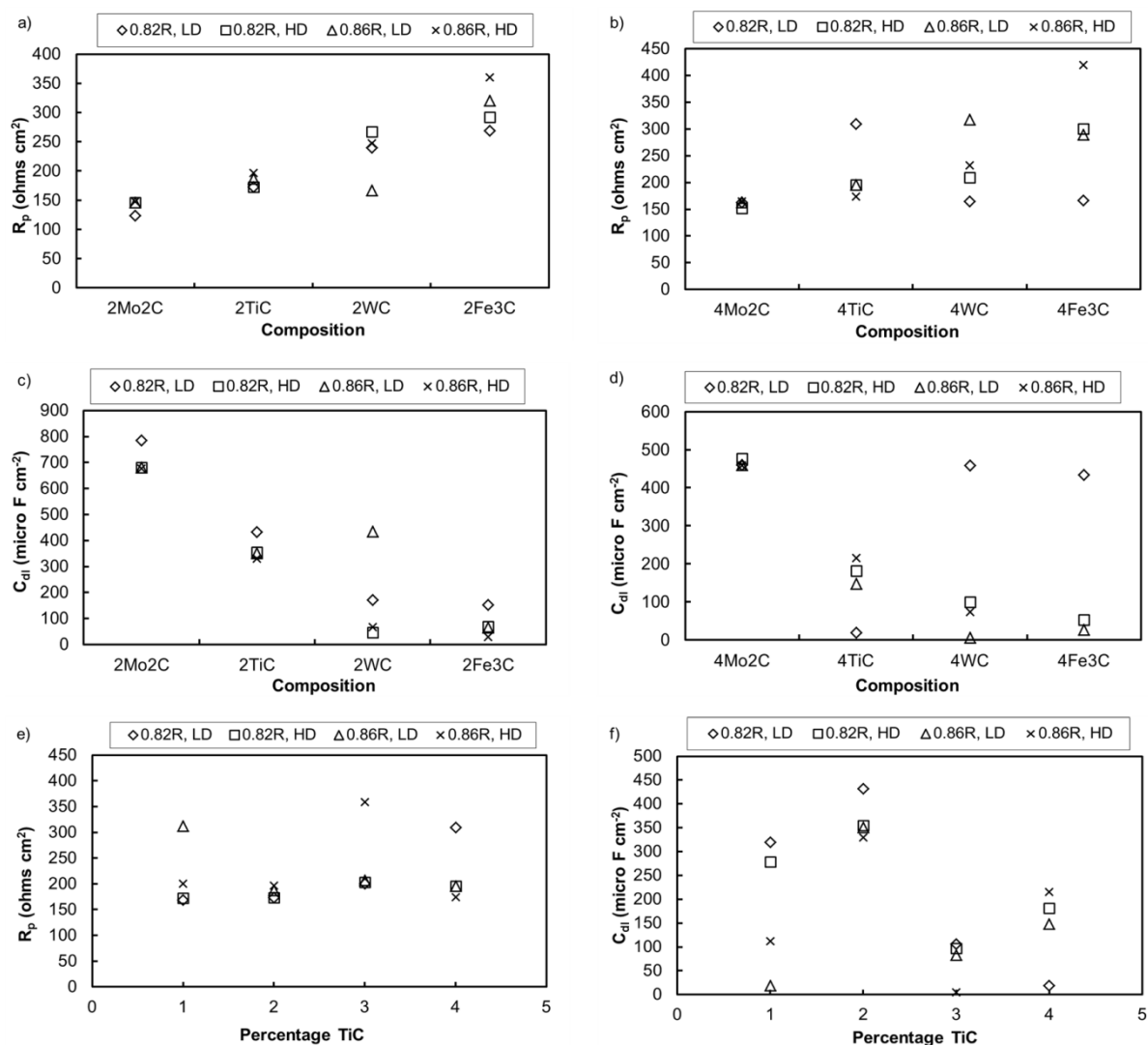

Figure 7: Variation of polarization resistance and double layer capacitance with respective carbide concentration in aluminum composites, (a and c) 2% carbide concentration, (b and d) 4% carbide concentration and (e and f) 1-4% TiC concentrations. All measurements are taken after 2 hours of immersion.

Further, the effect of initial relative density and percentage deformation is discussed here. Two preforms of 0.82 relative density and 0.86 relative density of each composite is taken and deformed to different height strain, low deformed and high deformed. It can be seen from Figure 7 that the higher initial relative density preform and highly deformed specimen showed greater material resistance to corrosion. This is clearly evident in Figure 7 (a-d) for Al₂Fe₃C, Al₂TiC, Al₄WC and Al₄Fe₃C. The effect of initial relative density and final height strain is almost negligible in Mo₂C reinforced aluminium composites, however, their effect is prominent in WC and Fe₃C reinforced aluminum composites. This also ties clearly with the micrographs present in Figures 3 and 4. Similar behavior is found when the TiC content is increased from 1 to 3%, however, the same is not true for 4% TiC content.

4.2.4. The significance of β -parameter

The presence of reinforcement in the matrix increases cathode to anode ratio in the composite, resulting in the formation of pits during localized corrosion. The β -parameter can be used to study the pitting corrosion. A higher β values indicates low corrosion and a low β values indicates higher corrosion. Figure 8 gives the variation of β for different composites tested in this research work with initial relative density and different levels of height strain. It is seen that β values are lower for Al₄Mo₂C and Al₂Mo₂C composite compared to other composites. It can be noted that the pitting corrosion resistance offered by the specimen is higher in Al₄Fe₃C and Al₂Fe₃C when having higher initial relative density and when it is highly deformed. Further, Al₃TiC showed lower β values when compared to other TiC reinforced aluminium composites. It can be noted that apart from Mo₂C reinforced aluminium composite, the lower initial relative density and low deformed preform of Al₄WC and Al₄Fe₃C showed very high pitting corrosion.

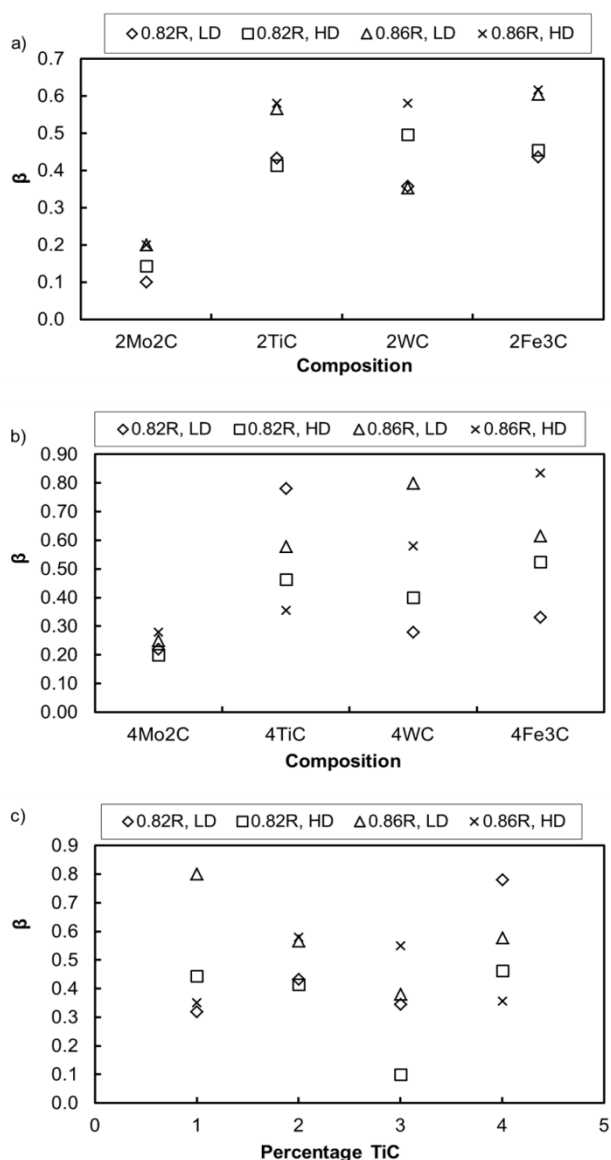

Figure 8: Variation of β -parameter with respective carbide concentration in aluminum composites, (a) 2% carbide concentration, (b) 4% carbide concentration and (c) 1-4% TiC concentrations. All measurements are taken after 2 hours of immersion.

From Figure 8 it can be noted that the β parameter is higher for higher initial relative density preforms and higher height strained preforms, except for Al4TiC composites. Higher initial relative density preforms usually archive higher final density after even secondary deformation and many researchers have presented the same [1-4]. This means that the number of pores present is less when final density attainment is high. Further, highly deformed specimen has lower number of pores in comparison to

lower height strain specimens. Since the corrosion specimens are taken from the center of the specimen, the pores present are usually round and spherical. These pores act as second phase particles and promote pitting corrosion. Hence, less number of pores are present in higher initial relative density and higher height strained specimens is the reason for high β values of these specimens suggesting lower pitting corrosion. Same can be seen in Figures 3 and 4.

5. Conclusion

The corrosion behaviors of Al1TiC, Al2TiC, Al3TiC, Al4TiC, Al2WC, Al4WC, Al2Fe₃C, Al4Fe₃C, Al2Mo₂C and Al4Mo₂C were studied in this research work. The following conclusions are drawn;

- The micrographs and electrochemical measurement strongly show that the Mo₂C reinforced aluminium composites has very poor material resistance to corrosion. Mo₂C reinforced aluminium composites further showed strong pitting corrosion irrespective of initial relative density and final height strain. It is noted that 2Fe₃C and 4Fe₃C reinforced aluminium metal matrix composite showed better corrosion resistance.
- The corrosion behavior is strongly dependent on the surface porosity. As expected, it was seen that higher porosity specimen produced lower corrosion resistance.
- The galvanostatic pulse technique using a typical three cell electrode configuration is utilized in this study to study the corrosion behavior of powder metallurgy materials. It is strongly noted that this technique can be successfully used for such studies.

Reference

- [1] Sahin Y. Preparation and some properties of SiC particle reinforced aluminium alloy composites. Mater Des 2003;24:671-9.
- [2] Eslamian M, Rak J, Ashgriz N. Preparation of aluminium/silicon carbide metal matrix composites using centrifugal atomization. Powder Technology 2008;184:11-20.
- [3] Narayanasamy R, Senthilkumar V, Pandey KS. Effect of titanium carbide particle addition on the densification behaviour of sintered P/M high strength steel preforms during cold upset forming. Mater Sci Eng A 2007;456:180-8.
- [4] Zhang XQ, Peng YH, Li MQ, Wu SC, Ruan XY. Study of workability limits of porous materials under different upsetting conditions by compressible rigid plastic finite element method. Journal of Materials Engineering and Performance 2009;9:164-169.

- [5] Gabe DR. Corrosion protection of sintered metal parts. *Powder metallurgy* 1977;20;227-231.
- [6] Nash MS. Surface treatment for corrosion protection of sintered iron parts. *Powder metallurgy* 1990;33(4);22-23.
- [7] Jinsun L, Hotta M, Mori Y. Improved corrosion resistance of a high-strength Mg-Al-Mn-Ca magnesium alloy made by rapid solidification powder metallurgy. *Materials Science and Engineering A* 2012;544;10-20.
- [8] Dobrzanski LA, Wlodarczyk A, Adamiak M. Structure, properties and corrosion resistance of PM composite materials based on EN AW-2124 aluminium alloy reinforced with the Al₂O₃ ceramic particles. *Journal of Materials Processing Technology* 2005;162-163;27-32.
- [9] Marchiori R, Maliska AM, Borges PC, Klein AN, Muzart. Corrosion study of plasma sintered unalloyed iron: The influence of porosity sealing and Ni surface enrichment. *Materials Science and Engineering A* 2007;467;159-164.
- [10] Neubert V, Smola B, Stulikova I, Bakkar A, Reuter J. Microstructure, mechanical properties and corrosion behavior of dilute Al-Sc-Zr alloy prepared by powder metallurgy. *Materials Science and Engineering A* 2007;464;358-364.
- [11] Mamatha GP, Pruthviraj RD, Ashok SD. Weight loss corrosion studies of aluminium-7075 metal matrix composites reinforced with SiC particulates in HCl solution. *International Journal of Research in Chemistry and Environment* 2011;1;85-88.
- [12] Etaat M, Emamy M, Ghambari M, Fadaei E. Surface treatment and nickel plating of iron powder metallurgy parts for corrosion protection. *Materials and Design* 2009;30;3560-3565.
- [13] Leisner P, Leu RC, Moller P. Electroplating of porous PM compacts. *Powder metallurgy* 1997;40;207-210.
- [14] Wick C, Veilleux RF. *Materials finishing and coating tool and manufacturing engineers hand book*. Society of Manufacturing Engineers 1985.
- [15] Beiss P. Steam treatment of sintered parts. *Powder metallurgy* 1991;34;173-177.
- [16] Chenghong Y, Hongyuan F, Ji X, Guo Z, Dong G, Wan W, Chen H. Effect of WC content on the microstructures and corrosion behavior of Ti(C, N) based cermets. *Ceramics International* 2013;39;503-509.
- [17] Chandramouli R, Kandavel TK, Shanmugasundaram D, Kumar TA. Deformation, densification and corrosion studies of sintered powder metallurgy plain carbon steel preforms. *Materials and Design* 2007;28;2260-2264.
- [18] Lei Z, Maicang Z, Jianxin D. Hot corrosion behavior of powder metallurgy Rene95 nickel-based superalloy in molten NaCl-Na₂SO₄ salts. *Materials and Design* 2011;32;1981-1989.

- [19] Kumar SMS, Rao KP, Girish DP. Corrosion rate and tensile strength of aluminium/SiC metal matrix composites in seawater. *International Journal of Advanced Engineering Research and Studies* 2012;1;313-315.
- [20] Alaneme KK, Bodunrin MO. Corrosion behavior of Alumina reinforced aluminium (6063) metal matrix composites. *Journal of Minerals and Materials Characterization and Engineering* 2011;10;1153-1165.
- [21] Bobic B, Mitrovic S, Babic M, Bobic I. Corrosion of aluminium and zinc-aluminium alloys based metal matrix composites. *Tribology in Industry* 2009;31;44-52.
- [22] Sharma SC. A study on stress corrosion behavior of Al6061/albite composite in higher temperature acidic medium using autoclave. *Corrosion Science* 2001;43;1877-1889.
- [23] Scully JR, *Corrosion* 2000;56;199-218.
- [24] Deo RN, Birbilis N, Cull JP. Measurement of corrosion in soil using galvanostatic pulse technique. *Corrosion Science* 2014;80;339-349.
- [25] Sherif ME, Almajid AA, Latif FH, Junaedi H. Effects of graphite on the corrosion behavior of aluminium graphite composite in sodium chloride solutions. *International Journal of Electrochemical Science* 2011;6;1085-1099.
- [26] Birbilis N, Nairn KM, Forsyth M. *Corrosion Science* 2003;43;1895-1902.
- [27] Lu C, Peiyu Y. *Corrosion Science* 2000;42;675-686.
- [28] M.G. Zuhair, M.A.Q. Amro, Corrosion behavior of powder metallurgy aluminium alloy 6061/Al₂O₃ metal matrix composites, The 6th Saudi Engineering Conference, Dhahran, 2002;5:271-280.
- [29] R.N. Deo, Geophysical methods for assessment of soil corrosivity, PhD thesis, School of Geosciences, Monash University, Melbourne, Australia, 2013.
- [30] N. Birbilis, B.W. Cherry, Monitoring the corrosion and remediation of reinforced concrete on-site: An alternative approach, *Materials and Corrosion*, 2005;56(4):237-243.
- [31] R.A.M. Anae, Study of corrosion behavior of Al-Si-Cu/WC composites in 0.1 N NaOH solution, *Journal of King Saud University - Engineering Sciences*, 2015;26(1):55-65.
- [32] D. Guangbiao, X. Ji, Y. Mei, G. Zhixing, W. Weicai, Y. Chenghong, Effect of Mo₂C on electrochemical corrosion behavior of Ti(C,N)-based cermets, *Journal of Central South University*, 2013;20:851-858.
- [33] H.C.A. Murthy, S.K. Singh, Influence of TiC particulate reinforcement on the corrosion behavior of Al 6061 metal matrix composites, *Advanced Materials Letters*, 2015;6(7):633-640.