



2016 IEEE International Symposium on Robotics and Intelligent Sensors, IRIS 2016, 17-20 December 2016, Tokyo, Japan

Smart Path Guidance Mobile Aid for Visually Disabled Persons

Utkal Mehta*, Mohammed Alim, Shivneel Kumar

School of Engineering & Physics, Faculty of Science, Technology & Environment, The University of the South Pacific (USP), Suva, Fiji.

Abstract

A traditional blind-navigation cane mostly used by a visually impaired person is not very appropriate mainly due to narrow search area. While a conventional cane warns of changes along the ground, it does not warn of other walking hazards and objects above a person's waist. There are many electronics based blind-navigation devices employ a voice guided GPS (global positioning system) and/or complex high-order processor. It is apparent that the costs of these devices are too high that a common visually impaired people cannot afford them. In addition, a kind of previous arts is difficult to handle due to the weight, volume and functions incubated with basic purpose. Therefore, these types of advanced navigation systems are difficult to be commercialized. The purpose of this research is to design and develop a smart path guidance system for the blind and visually impaired, particularly the mobile aid to carry by hand, contains a smart sensor logic system. An appropriate model has developed for the selected design with embedding fuzzy logic decision. A presented solution is also tested for various condition inputs to verify the system's behavior. Through several experiments, the sensors are calibrated to increase the accuracy of decision. The presented prototype enables the blind person to walk freely in an unfamiliar environment.

© 2017 The Authors. Published by Elsevier B.V. This is an open access article under the CC BY-NC-ND license (<http://creativecommons.org/licenses/by-nc-nd/4.0/>).

Peer-review under responsibility of organizing committee of the 2016 IEEE International Symposium on Robotics and Intelligent Sensors(IRIS 2016).

Keywords: Path guidance; smart sensor logic; fuzzy logic; visually disabled.

1. Introduction

Designing a device to aid a blind person is not something new. Various technologies have been used to aid the blind and as technologies get more and more advanced, ideas come up to make some very interesting solutions to aid the blind. However, designing a solution that is able to serve its purpose yet is so expensive that the aid becomes a so called luxurious item would not be most applicable in most developing countries. According to the World Health Organization (WHO) [1], 285 million people are estimated to be visually impaired worldwide of which around 39 million people are blind. Also, WHO estimates that most young blind children would need, for personal development, visual rehabilitation interventions. However, it usually comes with huge medical bills and with 90% of the visually impaired persons in the world living in low income settings, visual rehabilitation is not the best option for all.

For full psychological development and better independence without these huge bills, visually impaired persons need some sort of guide to help with their activities. This guide may be in the form of a walking stick, a guide dog, or even a human personal assistant. Another person may not always be available and not always preferred for a blind person that is looking for independence. The choice between a walking stick and a guide dog is a personal one that involves careful consideration of travel factors, lifestyles and preference.

*Corresponding author: Tel: (+679) 3232337
Email address: mehta_u@usp.ac.fj

Man’s best friend, the dog, may be specially trained to move around obstacles, stop at stairs or curbs and go through doorways. According to the Blind Foundation of New Zealand, to become a guide dog, puppies train for 2 years, walk thousands of steps and have to pass 55 tests [2]. Guide dogs are usually provided to blind people free of charge and costs are met through sponsorships, legacies and public donations. However, dogs may not be allowed in all places in public and like all living things they need constant care and this may be difficult to manage for a blind person. When compared to the cane, the guide dog can interact with the user and environment and prove more useful in certain locations but canes are usually preferred for reasons of price, allergies, and care [2].

The second and most preferred method is the cane or walking stick. Here, a white cane is used as a mobility tool enabling the user to move about safely and independently in most cases. It may also act as a symbol that the person carrying this white cane is blind or visually impaired. There are several types of canes and all have one feature in common – to find objects before the user hits them. However, this tool has flaws as well such as avoiding traffic, at times sensing depth and sometimes leave the user confused of its surrounding.

There is room for improvement on these canes to take them closer to faultlessness and precision. Installing electronic sensors and processing units will increase their accuracy and be able to guide the blind better and more effortlessly. From as early as 1962, ultrasonic has been experimented with in designing mobility aids for the blind [3]. It was unclear at that time how valuable this new development would be to the visually impaired because of the user’s psychological factors. It was concluded that a large number of blind people would have had to have undergone the trials and tests to have a clear indication on the viability of including ultrasonic into mobility aids for the blind. The late nineteen nineties gave way to research into the applications of robotics in the development of mobility aids for the elderly/frail blind [4]. Here, mobile robot technology enabled mobility aid supports the user walking behind it and allows it to avoid obstacles for a safe travel. Again, understanding the user’s needs was shown to be vital for an applicable design.

Interest grew into this area of research and soon a blind mobility aid modelled after progressing research reported in literature [2, 5, 6]. Mainly it has presented that new ICT enabled technology, a blind person could differentiate between several objects at the same time without virtual imagery. A mobility aid was evaluated based on psychophysical experiments. Convincingly enough, this technology still remains in the research phase and is yet to make it to production. It will most likely find its place with other higher end and more expensive designs – it does however solve the problem of differentiating between obstacles. Recently, a concept of path guidance robot was presented in [7] to control steering angle of the robot in simulation.

However sophisticated a concept is, one key factor still dictates the overall design – the user requirements. It is therefore apparent that a thorough study of the blind and visually impaired must be done to bring out the best design. Another factor greatly impacting the design is cost. As mentioned earlier, with a majority of the visually impaired persons in the world living in low income settings, the design has to be cheap enough to reach production/manufacture stage and possibly have a positive impact on the blind society.

In this work, a handy mobile device is developed for a visually impaired person. The portable electronic gadget is suitable to navigate by the user independently through signals such as vibrations, beeps and audio warnings. A prominent objective is to provide a mobility device, which is simple to handle and a low cost solution to replace a traditional navigation device. Another objective is to provide a smart cane to warn the user not only the detection of an object, but also the distance of object relative to the user and the distinguishing of the obstruction. The method includes the smart logical skills like human using fuzzy logic design and the micro-processor is programmed to deliver decision after information processing on traveling direction, pointing direction and previous decision results, and furthermore, delivers comfortable warnings.

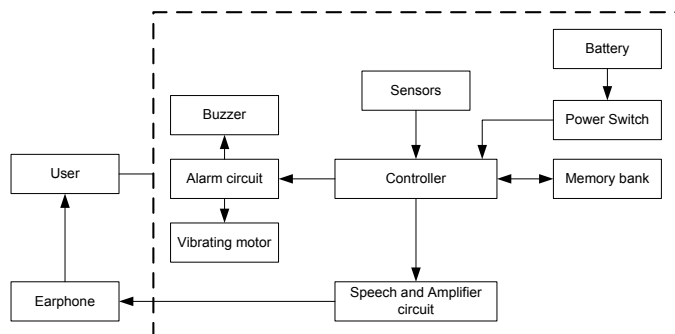

Fig. 1 Overall block diagram of the Smart Path Guidance Mobile

2. Modeling and Design

A smart mobile guidance mobile needs a controller that can handle the nonlinear inputs and uncertainties associated with it. Fig.1 shows the overall system block diagram that highlights the integration of various parts to satisfy the objectives. The device casing is responsible for housing all the components and having design suitable for the users. The electronic circuit comprises of the sensors, atmega328 microcontroller, power and input button circuitry and within the microcontroller, a fuzzy logic controller is implemented for the processing of data from sensors and controlling the output peripherals respectively.

2.1 Sensors calibration and modeling

The ultrasonic sensor used in this device has a measuring angle of 15 degrees according to the manufacturer’s specifications. It is important to measure the nonlinearity presents in sensors. We have calibrated the sensors practically for various ranges and obtained the error values with respect to actual distance of obstacles from the sensors. As shown in Fig.2, the error was within 1cm until 220cm where error started to increase. This error represents the difference between actual and projected distance using sensor. Then, the performance of the sensor logic circuit was enhanced using the mathematical model implemented in processing logic. From this experimental calibration, it was observed that sensor would fail to response correctly beyond 2 mt even though the upper limit suggested was 4 mt.

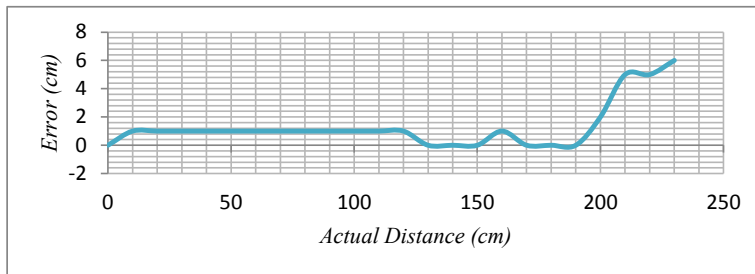

Fig. 2. Error relation with distance for ultrasonic sensor

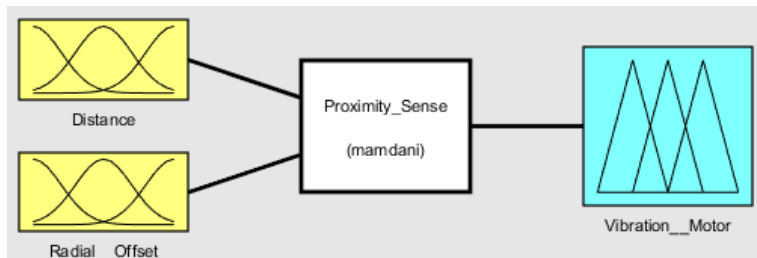

Fig. 3. Inputs and Outputs for fuzzy logic model

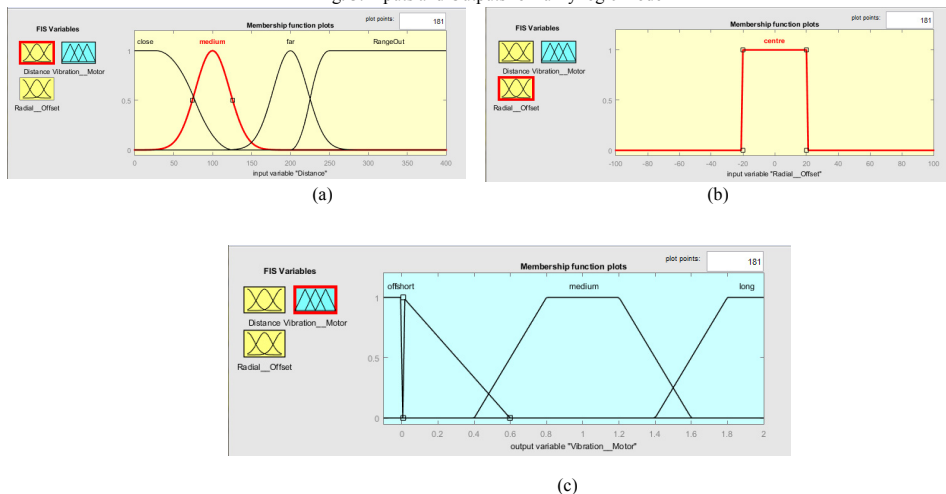

Fig. 4. MF for (a) Distance Membership; (b) Radial Offset; (c) Vibration Duration

2.2 Fuzzy logic modeling from reflections to warning

It is well-known that Fuzzy logic improves the system performance. In this work, an ultrasonic sensor takes inputs in the form of distance and radial offset from the obstacles. The sensor data is processed using microcontroller and decides on the duration of the vibration of the vibration motor. The basic logic is as follows: the longer the distance, the shorter the vibration. The system is modelled through fuzzy logic (Mamdani style) using the Fuzzy Logic Toolbox in MATLAB R2015a. Figs. 3 and 4 are shown input-output of fuzz logic model and membership function (MF) types, respectively.

Finally, following logic rules were implemented for programming microcontroller.

Rule 1. If (Distance is far) and (Radial_Offset is centre) then (Vibration_Motor is short)

Rule 2. If (Distance is medium) and (Radial_Offset is centre) then (Vibration_Motor is medium)

Rule 3. If (Distance is close) and (Radial_Offset is centre) then (Vibration_Motor is long)

Rule 4. If (Distance is RangeOut) or (Radial_Offset is not centre) then (Vibration_Motor is off)

2.3 Sensors working range

There are two ultrasonic sensors are used to cover to cover wider range of area in front. The top and bottom sensor are attached at 0 degrees and 40 degrees respectively as shown in Fig. 5. These angles have been chosen so that the device covers as much area as possible and yet are stable. Figure illustrates the coverage area and range of the device. The device is at 100cm off the ground vertically. The sensors' output is limited to 150cm as this is seen as the best distance to avoid any instability and sensors only operate in its accurate region. Also, the user does not need to know what is beyond 150cm if it is walking at normal pace as figured out after several successful trials.



Fig. 5. Sensor range and coverage area, isometric view

3. Prototype development and operational features

Aiming was to develop simple, low cost but effective design that has features like vibrations and sounds as the primary methods to alert users from any obstacles or walls. The prototype system has built in buzzer that sounds 3 times if there is an object on the ground or if there is a depth/rise on the ground. The vibrator vibrates according to the distance-vibration relationship described earlier if there is anything below 150cm of the device. In addition to this, the device has a feature of a battery warning algorithm that reads the battery level for every loop of the program and gives a buzzer warning if the battery level drops below 3V before cutting off the main program to avoid energy loss and deep discharge of the battery.



Top View



Front view

Fig.6. The isometric views of proposed mobile

The overall prototype isometric is shown in Fig. 6. The user can also check the battery level using right side button to press once.

If the battery is full, then 5 beeps will be produced by the buzzer. 4 beeps means the battery is 75% full, 3 beeps mean 50%, and so on until 1 beep which indicates a low battery level of 3.25V. There is also a sleep feature which cuts off the program and alert algorithms. This is done by pressing the centre button. This may be useful to the user if it wants to temporarily turn off the device and avoid constant buzzing and vibrations. To fully turn off the device, there is a slide switch at the back of the device that cuts off the power supply to the microcontroller. The rechargeable battery is charged through the port at the back of the device.

4. Conclusions and Discussions

Visually disabled persons have difficulty in distinguish and realize the real environment that they are not familiar with. In this paper, we proposed a concept to address the issue for visually impaired assistance. A final design was developed physically after complete synthesizing the sensor operations. In addition, simulation of the working of path guidance mobile device was performed and proved the capability of fuzzy decision in handling various positions and type of obstacles. An appropriate model has been created to test the behaviour of the system and simulations have been done to find flaws in the design. Several system modules dedicated to each feature of the design have been designed and put together. Finally, a 3D printed body was designed with considering para like aesthetics, ergonomics and size.

A final prototype was tested at the Fiji Blind Society and useful feedback was received by blind persons about its performance. This was done to verify if the device had any positive impact on blind persons' navigation and was therefore successful in helping the blind become more mobile. A few useful suggestions have also been made by the society on ways to improve the device.

The proposed device has been shown to work well within the budget and has achieved its major objectives – to be affordable and simple. The device's simplicity has been worked on and the final design is much simpler than the other electronic mobility aids built around the world.

References

1. T. Ifukube, T. Sasaki, C. Peng. A blind mobility aid modeled after echolocation of bats. *IEEE Transactions Biomedical Engineering*, 2002; **38(5)**: 461-465.
2. L. Gerard, M. Kenneth, H. Dawson. The application of robotics to a mobility aid for the elderly blind. *Robotics and Autonomous Systems*. 1998; **23(4)**: 245-252.
3. L. Kay. An Ultrasonic sensing probe as a mobility aid for the blind. *Ultrasonics*. 1964; **2(2)**:53-59.
4. Wikipedia contributors. Retrieved August 10,2015. White Cane [Online]
5. Maxbotix. Retrieved August 10,2015, Datasheet LV-MaxSonar-EZ [Online].
6. WHO report on Visual Impairment and Blindness. Retrieved August 10, 2015. [Online].
7. M.F. Razali, S.F. Toha, Z. Z. Abidin. Intelligent Path Guidance Robot for Visually Impaired Assistance. *Procedia Computer Science*. 2015; **76**:330-335.